



i/rd/image-in30000084

Korbtransportautomat
Automatic basket transport machines
Lave-vaisselle automatiques à transport de paniers

K 200 / K 400

A small icon of a globe with a red and blue grid pattern.

Ersatzteilliste
Spare parts list
Liste de pièces détachées

ERSATZTEILLISTE

SPARE PARTS LIST

LISTE DE PIECES DETACHEES



E-KT201
12/10/1995 - RD/EE

Typenreihe	K 200 / K400	gültig ab	Januar 1992
Type	K 200 / K400	valid from	January 1992
Série	K 200 / K400	valable à partir de	Janvier 1992

*Bei Ersatzteilbestellung sind folgende Angaben erforderlich:
Following information should be stated in your spare parts orders:
Veuillez indiquer s.v.p. les informations suivantes dans vos commandes.*

Kunde/Betreff: _____
Customer/Ref.: _____
Client/Objet: _____

MEIKO-Auftragsnummer _____
MEIKO-Serial No.: _____
No. de série MEIKO: _____

Maschinentype: _____
Type of machine: _____
Type de la machine: _____

Positions-Nr.: _____
Item No.: _____
Repère No.: _____

Benennung: _____
Denomination: _____
Dénomination: _____

Ersatzteilnummer: _____
Part No.: _____
Pièce No.: _____

Bei einigen Teilen sind zusätzliche Angaben nötig. Diese Teile sind in der Ersatzteilliste mit einem entsprechenden Hinweis versehen.

Some parts require more detailed information, these parts are especially stated in our list.

Il faut donner des informations supplémentaires pour quelques pièces.
Nous les avons munies de remarques spéciales.

ERSATZTEILLISTE

SPARE PARTS LIST

LISTE DE PIECES DETACHEES



E-KT201
12/10/1995 - RD/EE

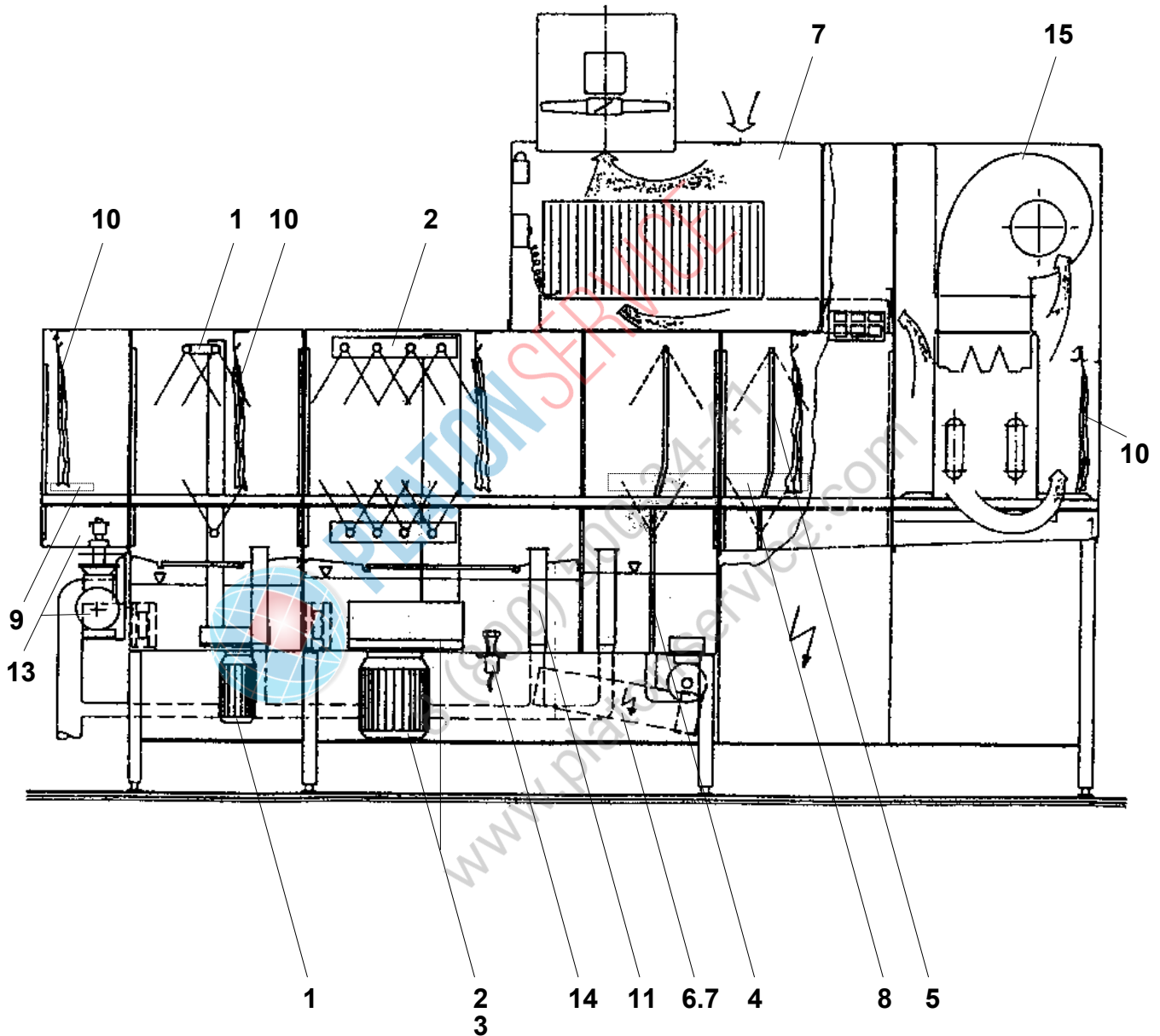

Schnittbild einer K-tronic - Maschine.

Sectional drawing of a K-tronic - machine.

Coupe d'une machine K-tronic.

Änderungen in Ausführung und Konstruktion vorbehalten. / We reserve the right to change execution and construction. / Nous nous reservons le droit de changer l'exécution et la construction.

ERSATZTEILLISTE

SPARE PARTS LIST

LISTE DE PIECES DETACHEES



E-KT201
12/10/1995 - RD/EE

INHALTSVERZEICHNIS		SOMMAIRE		CONTENTS	
1.0	WASCHPUMPE 0,55 KW + WASCHSYSTEM	WASH PUMP 0,55 KW + WASH SYSTEM	POMPE DE LAVAGE 0,55 KW + SYSTEME DE LAVAGE		
1.1	WASCHPUMPE 0,55 KW	WASH PUMP 0,55 KW	POMPE DE LAVAGE 0,55 KW		
1.2	STEIGROHR + WASCHSYSTEM LAVAGE	ASCENDING TUBE + WASH SYSTEM	TUYAU ASCENDANT+SYST. DE LAVAGE		
2.0	WASCHPUMPE 1,7 KW + WASCHSYSTEM	WASH PUMP 1,7 KW + WASH SYSTEM	POMPE DE LAVAGE 1,7 KW + SYSTEME DE LAVAGE		
2.1	WASCHPUMPE 1,7 KW	WASH PUMP 1,7 KW	POMPE DE LAVAGE 1,7 KW		
2.2	STEIGROHR	ASCENDING TUBE	TUYAU ASCENDANT		
2.3	BLOCKWASCHSYSTEM	BLOC WASH SYSTEM	SYSTEME DE LAVAGE EN BLOC		
2.4	SEITLICHES WASCHSYSTEM	LATERAL WASH SYSTEM	SYSTEME DE LAVAGE LATERAL		
3.0	WASCHPUMPE 2,2 KW + WASCHSYSTEM	WASH PUMP 2,2 KW + WASH SYSTEM	POMPE DE LAVAGE 2,2 KW + SYSTEME DE LAVAGE		
3.1	WASCHPUMPE 2,2 KW	WASH PUMP 2,2 KW	POMPE DE LAVAGE 2,2 KW		
4.0	PUMPENKLARSPÜLUNG	PUMP FINAL RINSING	RINCAGE FINAL A POMPE		
4.1	PUMPENMOTOR 0,5 KW	PUMP MOTOR 0,5 KW	MOTEUR DE POMPE 0,5 KW		
4.2	STEIGROHR + SPRÜHARME	ASCENDING TUBE + SPRAY ARMS	TUYAU ASCENDANT+BRAS DE LAVAGE		
5.0	FRISCHWASSERKLARSPÜLUNG	FRESH WATER RINSING	RINCAGE FINAL A EAU CLAIRE		
5.1	STEIGROHR + SPRÜHARME	ASCENDING TUBE + SPRAY ARMS	TUYAU ASCENDANT+BRAS DE LAVAGE		
6.0	FRISCHWASSERINSTALLATION	FRESH WATER INSTALLATION	INSTALLATION A EAU CLAIRE		
6.1	RÜCKSAUGEVERHINDERUNGS- EINRICHTUNG	ANTI-REFLUX DEVICE	DISPOSITIF ANTI-RETOUR		
6.2	SCHMUTZFÄNGER	DIRT TRAP	COLLECTEUR DE BOUE		
6.3	MAGNETVENTIL FÜR KLARSPÜLUNG	SOLENOID VALVE FOR FINAL RINSE	ELECTROVANNE P. RINCAGE FINAL		
6.4	MAGNETVENTIL FÜR TANKFÜLLUNG REMPLISSAGE/BAC	SOLENOID VALVE FOR TANK FILLING	ELECTROVANNE P.		
6.5	ÜBERDRUCKVENTIL	OVERPRESSURE VALVE	SOUPAPE DE SURPRESSION		
6.6	DRUCKMINDERVENTIL	PRESSURE REDUCING VALVE	DETENDEUR DE PRESSION		
6.7	DURCHLAUFERHITZER DAMPF	BOILER STEAM	SURCHAUFFEUR VAPEUR		
6.8	DURCHLAUFERHITZER ELEKTRISCH	BOILER ELECTRICAL	SURCHAUFFEUR ELECTRIQUE		
6.9	BOILER FÜR DEMI-WASSER	BOILER FOR DEMI-WATER	SURCHAUFFEUR POUR EAU DEMI		

Änderungen in Ausführung und Konstruktion vorbehalten. / We reserve the right to change execution and construction. / Nous nous reservons le droit de changer l'exécution et la construction.

ERSATZTEILLISTE

SPARE PARTS LIST

LISTE DE PIECES DETACHEES



E-KT201
12/10/1995 - RD/EE

INHALTSVERZEICHNIS SOMMAIRE CONTENTS			
7.0	ABLUFTWÄRMERÜCKGEWINNUNG	WASTE AIR HEAT RECOVERY	RECUPERATION D'ENERGIE
7.1	WÄRMETAUSCHER (CU)	HEAT EXCHANGER (CU)	SURCHAUFFEUR (CU)
7.2	WÄRMETAUSCHER (CRNI)	HEAT EXCHANGER (CRNI)	SURCHAUFFEUR (CRNI)
7.3	AXIALGEBLÄSE	AXIAL FAN	VENTILATEUR AXIAL
7.4	RADIALGEBLÄSE, MRL	RADIAL FAN, MRL	VENTILATEUR RADIAL, MRL
8.0	FRISCHWASSERSPARSCHALTER	FRESH WATER SAVING DEVICE	INT. ECONOMISEUR - EAU DE RINCAGE
8.1	FRISCHWASSERSPARSCHALTER F. MASCHINEN O. PU-KLARSPÜLUNG	FRESH WATER SAVING DEVICE FOR MACHINES WITHOUT PU. FINAL RINSE	INT. ECONOMISEUR-EAU DE RINCAGE P. MACHINES SANS RINCAGE A POMPE
8.2	FRISCHWASSERSPARSCHALTER F. MASCHINEN M. PU-KLARSPÜLUNG	FRESH WATER SAVING DEVICE FOR MACHINES WITH PUMP FINAL RINSE	INT. ECONOMISEUR-EAU DE RINCAGE P. MACHINES AVEC RINCAGE A POMPE
9.0	EINLAUFTAKTSCHALTER	FEEDING INTERVAL SWITCH	INTERRUPT. DE SYNCHRONISATION D'ENTREE MACHINE
10.0	SPRITZSCHUTZVORHANG	CURTAIN	RIDEAU
11.0	TANKABLAUF	TANK DRAIN	VIDANGE DE BAC
12.0	HUBTÜREN	LIFTING DOOR	PORTE
12.1	TÜRFÜHRUNG	DOOR GUIDANCE	GUIDAGE DE PORTE
12.2	GEWICHTSAUSGLEICH	COUNTER WEIGHT	POIDS DE PORTE
13.0	KORBTRANSPORTEINHEIT	BASKET TRANSPORT DEVICE	SYSTEME DE TRANSPORT
13.1	MOTOREINHEIT	MOTOR UNIT	MOTEUR DE TRANSPORT
13.2	KORBTRANSPORTSCHLITTEN	BASKET TRANSPORT SLIDE	COULISSEAU DE TRANSPORT
13.3	TISCHENDSCHALTER	TABLE END SWITCH	INTERRUPTEUR FIN DE COURSE
14.0	TANKHEIZUNG	TANK HEATING ELEMENT	RESISTANCE DU BAC
14.1	TANKHEIZKÖRPER ELEKTRISCH (GEWINDE)	TANK HEATING ELEMENT ELECTRICAL (THREAD)	RESISTANCE DE CHAUFFAGE ELECTR. (FILETE)
14.2	TANKHEIZKÖRPER ELEKTRISCH (FLANSCH)	TANK HEATING ELEMENT ELECTRICAL (FLANGE)	RESISTANCE DE CHAUFFAGE ELECTR. (BRIDE)
14.3	TANKHEIZSCHLANGE FÜR NIEDERDRUCKDAMPF HOCHDRUCKDAMPF PUMPENHEIßWASSER	TANK HEATING ELEMENT FOR HIGH PRESSURE STEAM LOW PRESSURE STEAM PUMP HOT WATER	SERPENTIN DE CHAUFFAGE POUR VAPEUR BASSE PRESSION VAPEUR HAUTE PRESSION EAU CHAUDE A POMPE

Änderungen in Ausführung und Konstruktion vorbehalten. / We reserve the right to change execution and construction. / Nous nous reservons le droit de changer l'exécution et la construction.

ERSATZTEILLISTE

SPARE PARTS LIST

LISTE DE PIECES DETACHEES



E-KT201
12/10/1995 - RD/EE

INHALTSVERZEICHNIS

SOMMAIRE

CONTENTS

15.0	TROCKNUNGSZONE	DRYING SECTION	SECTION DE SECHAGE
15.1	RADIALGEBLÄSE	RADIAL FAN	VENTILATEUR RADIAL
15.2	HEIZREGISTER, ELEKTRISCH	HEATING REGISTER, ELECTRICAL	REGISTRE DE CHAUFFAGE ELECTR.
15.3	HEIZREGISTER, DAMPF	HEATING REGISTER, STEAM	REGISTRE DE CHAUFFAGE; VAPEUR
16.0	DAMPFINSTALLATION	STEAM INSTALLATION	INSTALLATION DE VAPEUR
16.1	ABSPERRSCHIEBER	STOP BAFFLE	CLAPET D'ARRET
16.2	ABSPERRVENTIL	STOP VALVE	VANNE D'ARRET
16.3	SCHMUTZFÄNGER DAMPF	DIRT TRAP STEAM	COLLECTEUR DE BOUE VAPEUR
16.4	SCHMUTZFÄNGER DAMPF	DIRT TRAP STEAM	COLLECTEUR DE BOUE VAPEUR
16.5	MAGNETVENTIL DAMPF	SOLENOID VALVE STEAM	ELECTROVANNE VAPEUR
16.6	MENGENREGULIERVENTIL	VOLUME CONTROLLING VALVE	VANNE DE REGULATION DE VOLUME
16.7	AUSTAUSCHSATZ FÜR STELLVENTIL DAMPF	REPLACEMENT KIT FOR CONTROL VALVE STEAM	JEU DE REMPLACEMENT POUR VANNE DE CONTROL VAPEUR
16.8A	STELLVENTIL DAMPF	CONTROL VALVE STEAM	VANNE DE CONTROL VAPEUR
16.8B	ERSATZ FÜR POSITION 16.8A	REPLACEMENT FOR POS. 16.8A	REPLACEMENT POS. 16.8A
16.9	VORSTEUERVENTIL ZU POS. 16.8A	PRECONTROL VALVE FOR POS. 16.8A	VANNE PILOTE POUR POS. 16.8A
16.10	KONDENSATABLEITER	STEAM TRAP	SEPARATEUR DE VAPEUR
16.11	KONDENSATABLEITER	STEAM TRAP	SEPARATEUR DE VAPEUR
17.0	ELEKTROINSTALLATION	ELECTRICAL INSTALLATION	INSTALLATION ELECTRIQUE
17.1	DURCHFLUßWÄCHTER	FLOW CONTROL	DEBIT METRE
17.2	MAGNETSCHALTER	MAGNETIC SWITCH	INTERRUPTEUR AIMANT
17.3	NÄHERUNGSSCHALTER FÜR DEMI	PROXIMITY SWITCH FOR DEMI	DETECTEUR DE PROXIMITE P. DEMI
17.4	THERMOSTAT	THERMOSTAT	THERMOSTAT
17.5	MAGNETSCHALTER	MAGNETIC SWITCH	INTERRUPTEUR AIMANT
18.0	ZUBEHÖR	ACCESSORIES	ACCESSOIRES
18.1	DRUCKERHÖHUNGSPUMPE	BOOSTER PUMP	SURPRESSEUR
18.2	FERNTHERMOMETER	TEMPERATURE GAUGE	TELETHERMOMETRE
18.3	THERMOSTAT	THERMOSTAT	THERMOSTAT
18.4	MASCHINENSTOLLEN	FEET FOR MACHINE	PIEDS DE MACHINE
18.5	SCHWIMMER FÜR NIVEAUREGLER	FLOAT FOR LEVEL REGULATOR	FLOTTEUR P. REGLAGE DE NIVEAU
18.6	FROSTSCHUTZWÄCHTER	ANTI-FREEZE PROTECTION	PROTECTEUR ANTI-GEL
18.7	WASCHLAUGENZYKLON	CYCLONE	CYCLONE

Änderungen in Ausführung und Konstruktion vorbehalten. / We reserve the right to change execution and construction. / Nous nous reservons le droit de changer l'exécution et la construction.

POS. 1.1 WASCHPUMPE 0,55 KW CRNI, 50 HZ



POS. 1.1 WASH PUMP 0,55 KW CRNI, 50 HZ

POS. 1.1 POMPE DE LAVAGE 0,55 KW CRNI, 50 HZ

POS.	IDENT.-NR. IDENT.-NO.	BEZEICHNUNG	DESIGNATION	DESIGNATION
1	8100171	MOTORTRAEGER PP D 110X20-10	MOTOR SUPPORT D110 X 10 MM PP	SUPPORT DE MOTEUR D110 X 10 MM PP
2	8100173	FLANSCH-MOTORTRÄGER KPL. GEPUNKTET <u>UND</u>	FLANGE FOR MOTOR SUPPORT READY TO BE INSTALLED	FLASQUE POUR SUPPORT DE MOTEUR PRET A ETRE MONTE
3	8101079	PUMPENBODEN KOMPL. 0,55KW	PUMP BASE 0,55 KW CPL.	READY FOND DE POMPE 0,55 KW CPL.
4	0403013	GLEITR.-MANSCHETTE WINKEL 17 X 27 X 5 MM EPDM	ANGLE COLLAR 17 X 27 X 5 MM	MANCHETTE EN ANGLE 17 X 27 X 5 MM
5	0501015	MOTOR RF 0,37/2-7 0,55KW 380-415/220-240V	PUMP MOTOR WITH IMPELLER 220/380 V,2.8000 RPM.	MOTEUR DE POMPE A.AUBE DE VENTIL220/380V,2800TR/MIN
6	0403014	GLEITRING SPR-E23 KERAMIK 15 X 25 X 6 MM	SLIDING RING CERAMICS 15 X 25 X 6 MM	BAGUE CERAMICS 15 X 25 X 6 MM
7	0403001	GLEITRINGDICHTUNG 15 X 30 MM EPDM	SLIDING SEAL 15 X 30	JOINT AXIAL 15 X 30 MM
8	0302043	SKT.-SCHRAUBE M 5X10 A2 DIN 933	HEXAGON SCREW M5X10, DIN 933,4301	VIS A 6 PANS M5X10, DIN 933, 4301
9	0620134	<u>BEI 50 HZ BETRIEB</u> PUMPENRAD K134 ABGEDREHT	<u>WITH 50 CYCLES OPERATION</u> IMPELLER K 134	<u>FONCTIONNEMENT A 50 CYCLES</u> ROUE DE POMPE K 134
	8130697	<u>BEI 60 HZ BETRIEB</u> PUMPENRAD K134 K ABGEDREHT D=70	<u>WITH 60 CYCLES OPERATION</u> IMPELLER K 134 OFF D=70	<u>FONCTIONNEMENT A 60 CYCLES</u> ROUE DE POMPE K 134 REDUIT A UN DIAM. DE 70
	8680023	<u>BEI 220V 50 HZ BETRIEB</u> PUMPENRAD K134 K	<u>WITH 220V 50 CYCLES OPERATION</u> IMPELLER K 134	<u>FONCTIONNEMENT A 220V 50 CYC.</u> ROUE DE POMPE K 134
10	0340006	U-SCHEIBE MS. VERN. 8,4 X 18 X 2 MM	WASHER BRASS NICKED 8,4 X 18 X 2 MM	RONDELLE 8,4 X 18 X 2 EN LAITON NICKELE
11	0336005	HUTMUTTERN MS. VERN. DIN 1587 M 8	CAP NUT M 8 DIN 1587	ECROU CHAPEAU M 8 DIN 1587
12	8101080	PUMPEN-DECKEL 0,55 KW 207X206,5X73	PUMP LID 0,55 KW 207X206,5X73	COUVERCLE DE POMPE 0,55 KW 207X206,5X73
13	0340010	U-SCHEIBE 1.4301 6,3X16X1,5 MM	WASHER 4301 16 X 6,3 X 1,5 MM	RONDELLE 16 X 6.3 X 1,5MM 4301
14	0337001	SKT.-MUTTER M 5 A4 SELBSTSICH. DIN 985	HEXAGON NUT SELFFIXING M5 4401 DIN 985	ECROU A SIX PANS M5 4401 DIN 985
15	0302043	SKT.-SCHRAUBE M 5X10 A2 DIN 933	HEXAGON SCREW M5X10, DIN 933,4301	VIS A 6 PANS M5X10, DIN 933, 4301
16	0337005	SKT.-MUTTER M 8 A4 SELBSTSICH. DIN 985	HEXAGON NUT M 8, 4301 DIN 985	ECROU A SIX PANS M8, 4301

POS. 1.1 WASCHPUMPE 0,55 KW CRNI, 50 HZ



POS. 1.1 WASH PUMP 0,55 KW CRNI, 50 HZ

POS. 1.1 POMPE DE LAVAGE 0,55 KW CRNI, 50 HZ

POS.	IDENT.-NR. IDENT.-NO.	BEZEICHNUNG	DESIGNATION	DESIGNATION
------	--------------------------	-------------	-------------	-------------

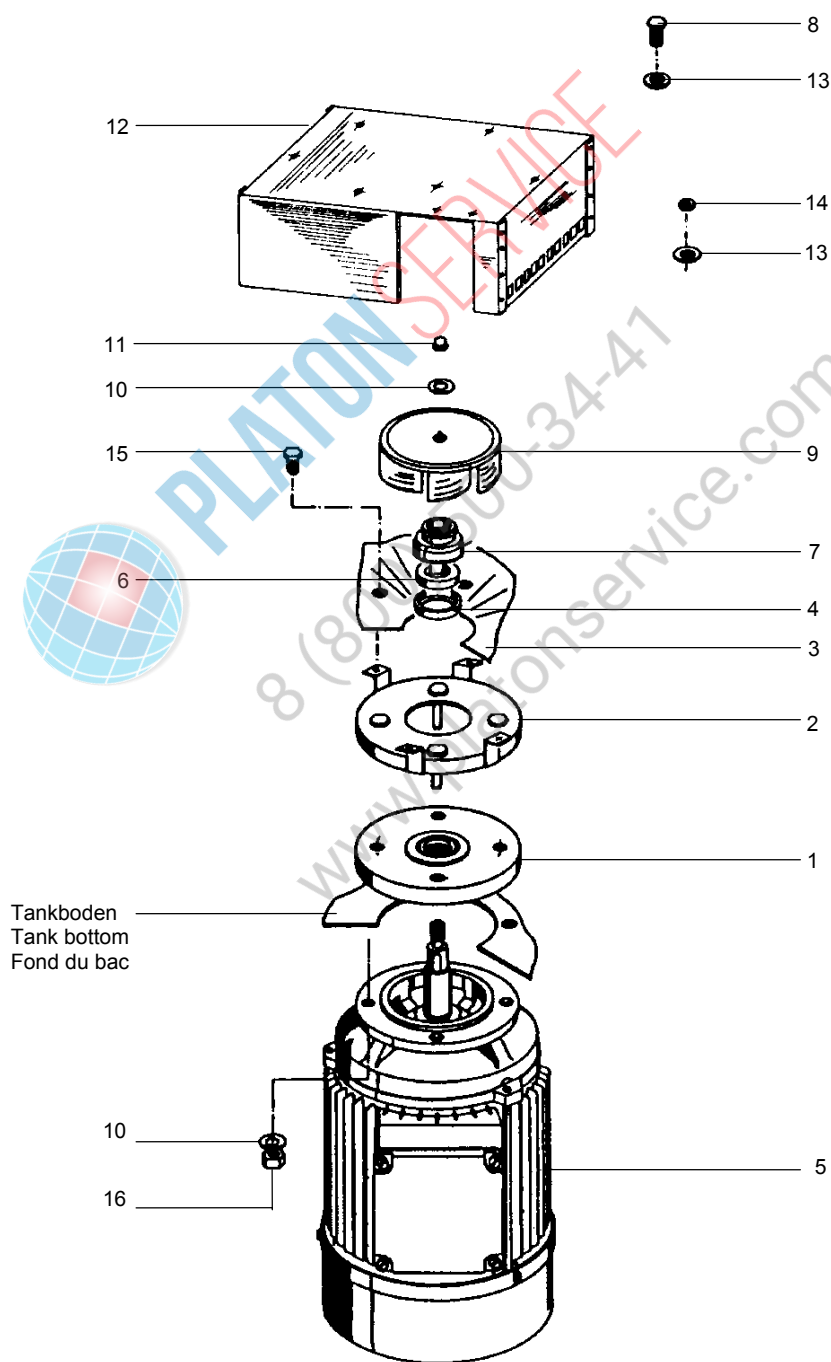

ird\image-in\30000026

POS. 1.2 STEIGROHR + WASCHSYSTEM



POS. 1.2 ASCENDING TUBE + WASH SYSTEM

POS. 1.2 TUYAU ASCENDANT + SYSTEME DE LAVAGE

POS.	IDENT.-NR. IDENT.-NO.	BEZEICHNUNG	DESIGNATION	DESIGNATION
1	8132110-01	STEIGROHR SCHWEIßTEIL L-R 0,55 KW	ASCENDING PIPE WELDING PART 0,55 KW	tuyau ascendant PIECE A SUDER 0,55 KW
2	8132110-02	STEIGROHR SCHWEIßTEIL R-L 0,55 KW	ASCENDING PIPE WELDING PART 0,55 KW	tuyau ascendant PIECE A SUDER 0,55 KW
3	8130265	WASCHROHR UNTEN 0,55 KW KOMPL.M.VERSCHLUßKAPPE	WASH ARM BELOW 0,55 KW K200-22.03.01.4	BRAS DE LAVAGE INFERIEUR 0,55KW K200-22.03.01.4
4	8130263	WASCHARM OBEN 0,55 KW KOMPL.M.VERSCHLUßKAPPE	WASH ARM ABOVE 0,55 KW K200-22.02.01.4	BRAS DE LAVAGE SUPERIEUR 0,55 KW K200-22.02.01.4
5	0620292	VERSCHLUSSKAPPE K292	CLOSING CAP K292	CAPUCHON K292
6	8102042	VERSCHLUßKAPPE D=34,2X1,5 D=42X14 4301	CLOSING CAP 1" CRNI D34.2 X 1.5 MM	CAPUCHON 1" CRNI D34.2 X 1.5 MM
7	0321015	SCHAFTSCHRAUBE DIN 427 M6 X 15 MM W.-	SCREW M 6X15,DIN 427,	VIS M 6X15,DIN 427,4301

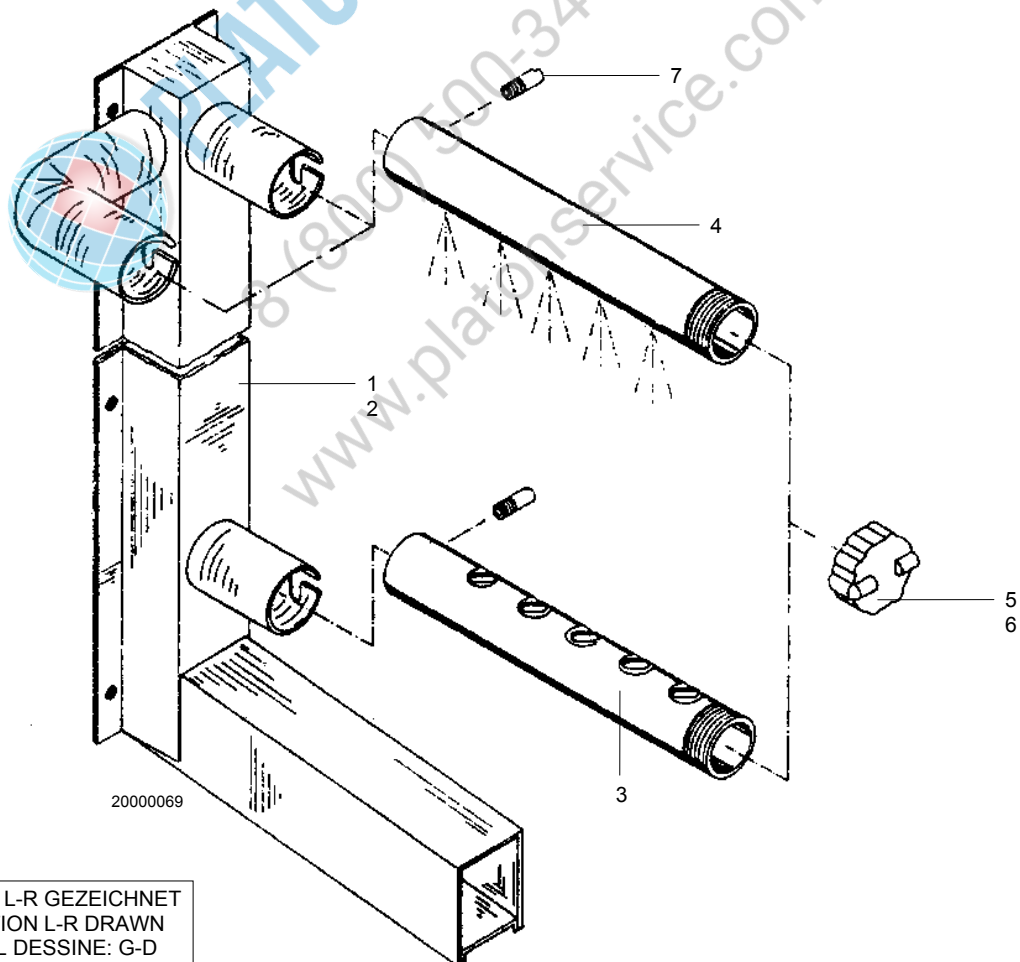

ARBEITSRICHTUNG L-R GEZEICHNET
WORKING DIRECTION L-R DRAWN
SENS DE TRAVAIL DESSINE: G-D

POS. 2.1 WASCHPUMPE 1,7 KW CRNI 50 HZ



POS. 2.1 WASH PUMP 1,7 KW CRNI 50 HZ

POS. 2.1 POMPE DE LAVAGE 1,7 KW CRNI 50 HZ

POS.	IDENT.-NR. IDENT.-NO.	BEZEICHNUNG	DESIGNATION	DESIGNATION
1	0501018	MOTOR AM90SY2 V3 1,7 KW IP54F 220/240-380/415V	MOTOR AM90SY2 V3 1,7 KW IP54F 220/240-380/415V	MOTEUR AM90SY2 V3 1,7 KW IP54F 220/240-380/415V
2	0335015	SECHSKANTMUTTERN DIN 934 W.-NR. 1.4301 M 8	HEXAGON NUT M 8 4301 DIN 934	ECROU A 6 PANS M 8 4301 DIN 934
3	0340006	U-SCHEIBE MS. VERN. 8,4 X 18 X 2 MM	WASHER BRASS NICKELED 8,4 X 18 X 2 MM	RONDELLE 8,4 X 18 X 2 EN LAITON NICKELE
4	0620333	MOTORTRAEGER K 331	MOTOR SUPPORT K 331	SUPPORT DE MOTEUR
5	8101063	FLANSCH MIT DISTANZBOLZEN Ø=150	FLANGE WITH DISTANCE BOLT Ø=150	FLASQUE P. SUPPORT DE PAN Ø=150
6	8100824	PUMPENBODEN 2,2 KW KOMPL.	PUMP BASE 2,2 KW CPL.	FOND DE POMPE CPL. 2,2 KW
7	0403009	GLEITR.-MANSCHETTE WINKEL 30 X 40 X 7 MM 480000008	COLLAR PERBUNAN 30X40X7 480 000 008	MANCHETTE PEBUNAN 30X40X7,480 000 008
8	0403010	GLEITRING KERAMIK 25 X 38 X 8 MM	SLIDING SEAL CERAMICS 25 X 38 X 8 MM	JOINT AXIAL CERAMIQUE 25 X 38 X 8 MM
9	0403003	GLEITRINGDICHTUNG 25 X 44 X 20 MM	SLIDING SEAL 25 X 44 X 20 MM	JOINT AXIAL 25 X 44 X 20 MM
10	0340010	U-SCHEIBE 1.4301 6,3X16X1,5 MM	WASHER 4301 16 X 6,3 X 1,5 MM	RONDELLE 16 X 6,3 X 1,5MM 4301
11	0302000	SECHSKANTSCHRAUBE DIN 933 M 6 X 10 MM, W.-NR.1.4301	HEXAGON SCREW M 6X10 4301,DIN 933	VIS A 6 PANS M 6X10 4301,DIN 933
12	0355105	PAßFEDER 4301 8X7X22MM	KEY 4301 8X7X22MM	RESSORT D'AJUSTAGE 4301 8X7X22MM
13	8101620	PUMPENRAD <u>1.7KW/50HZ</u> 120MM, V2A	PUMP WHEEL <u>1.7KW/50HZ</u> 120MM, V2A	ROUE DE POMPE <u>1.7KW/50HZ</u> 120MM, V2A
	8101625	PUMPENRAD <u>1.7KW/60HZ</u> 108MM, V2A	PUMP WHEEL <u>1.7KW 60HZ</u> D=108 SS304	ROUE DE POMPE <u>1.7KW/60HZ</u> D=108 SS304
14	8100251	U-SCHEIBE D=34 X 7 X 2 4301	WASHER D=34X7X2 4301	RONDELLE D=34X7X2 4301
15	0302001	SECHSKANTSCHRAUBE DIN 933 M 6 X 15 MM, W.-NR.1.4301	HEXAGON SCREW M6 X 15, 4301	VIS A 6 PANS M 6 X 15, 4301
16	8100823	PUMPENDECKEL 2.2 KW 4301	PUMP LID FOR PUMP 2,2 KW 4301	COUVERCLE DE POMPE POUR POMPE 2,2KW 4301
17	0302043	SECHSKANTSCHRAUBE DIN 933 M5 X 10 W.-NR. 1.4301	HEXAGON SCREW M5X10, DIN 933,4301	VIS A 6 PANS M5X10, DIN 933, 4301
18	0337001	SECHSKANTMUTTERN SELBST- SICHERND 4401 M5 DIN 985	HEXAGON NUT SELFFIXING M5 4401 DIN 985	ECROU A SIX PANS M5 4401 DIN 985

POS. 2.1 WASCHPUMPE 1,7 KW CRNI 50 HZ



POS. 2.1 WASH PUMP 1,7 KW CRNI 50 HZ

POS. 2.1 POMPE DE LAVAGE 1,7 KW CRNI 50 HZ

POS.	IDENT.-NR. IDENT.-NO.	BEZEICHNUNG	DESIGNATION	DESIGNATION
------	--------------------------	-------------	-------------	-------------

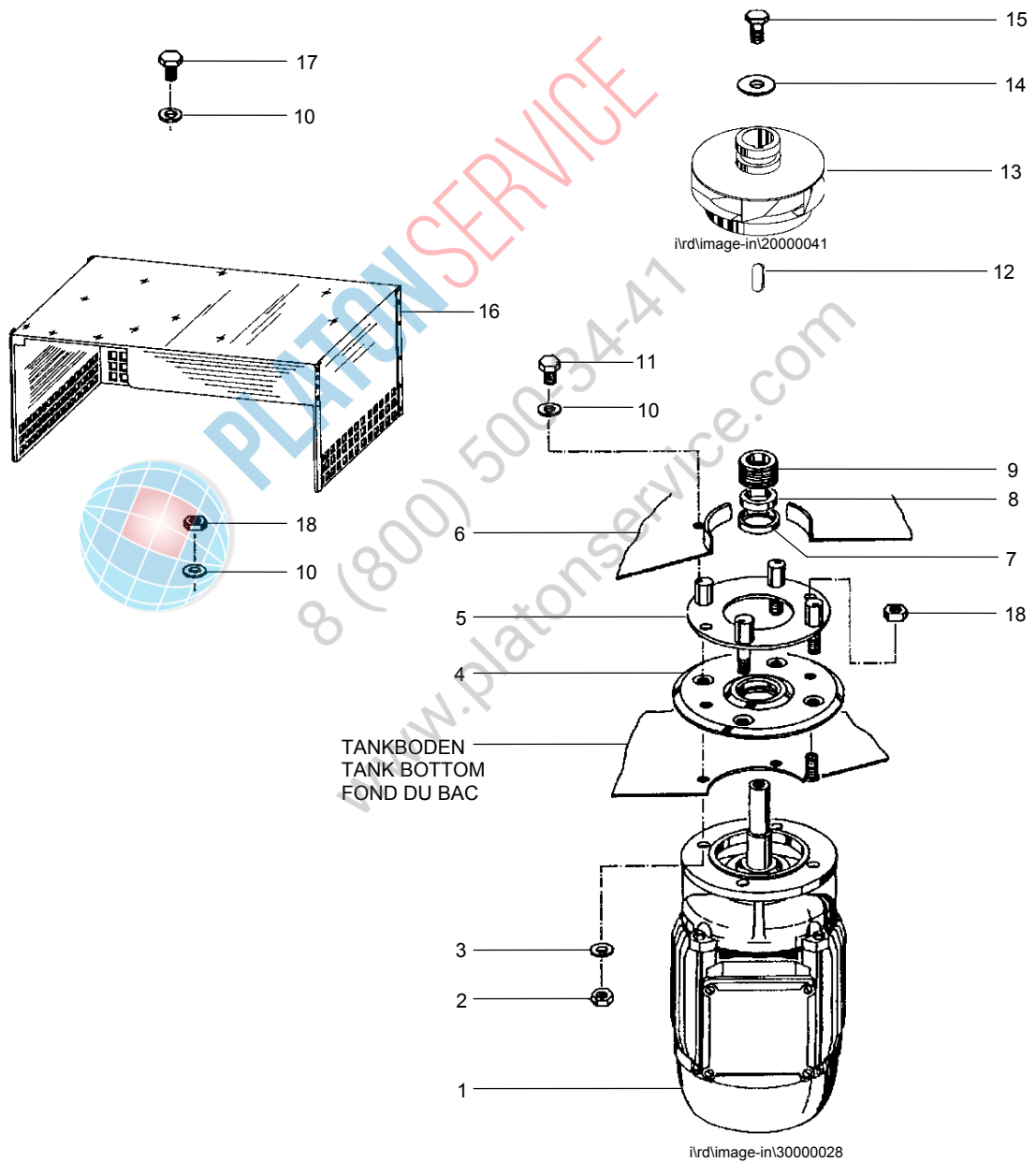

POS. 2.2 STEIGROHR 1,7/2,2 KW



POS. 2.2 ASCENDING PIPE 1,7/2,2 KW

POS. 2.2 TUYAU ASCENDANT 1,7/2,2 KW

POS.	IDENT.-NR. IDENT.-NO.	BEZEICHNUNG	DESIGNATION	DESIGNATION
		WAHLWEISE	OPTIONAL	AVOLONTE
1	8132116	STEIGROHR MIT ZYKLON-BOHRUNG	ASCENDING PIPE COMPL.WITH CYCLONE CONNECTION	TUYAU ASCENDANT COMPL. AVEC ALESAGE CYCLONE
		ODER	OR	OU
2	8132117	STEIGROHR KPL.O. ZYKLON-BOHRUNG EINBAUFERTIG	ASCENDING PIPE CPL. BUT W/O CYCLONE CONNECTION	TUYAU ASCENDANT COMPL SANS ALESAGE CYCLONE
3	0337001	SECHSKANTMUTTER SELBST-SICHERND 4401 M5 DIN 985	HEXAGON NUT SELFFIXING M5 4401 DIN 985	ECROU A SIX PANS M5 4401 DIN 985
4	0340010	U-SCHEIBE 4301 16 X 6,3 X 1,5 MM	DISC 16 X 6,3 X 1,5 MM 4301	RONDELLE 16 X 6.3 X 1,5MM 4301
5	8130284	DROSSELBLECH 143X32X1,25	THROTTLE PLATE 143X32X1,25	TOLE DE D'ETRANGLEMENT 143X32X1,25
6	8132118-02	FÜHRUNG OBERES WASCHSYSTEM L-R	GUIDANCE UPPER WASH SYSTEM L-R	GUIDAGE DE LAVAGE SUPERIEUR G-D
7	8132118-01	FÜHRUNG OBERES WASCHSYSTEM R-L	GUIDANCE UPPER WASH SYSTEM R-L	GUIDAGE DE LAVAGE SUPERIEUR D-G
8	8132185-01	FÜHRUNG STEIGROHRSEITE GEPUNKTET L-R	GUIDANCE ASCENDING PIPE POINT WELDED L-R	GUIDAGE TUYAU ASCENDANT COTE EN POINTILES G-D
9	8132186-01	FÜHRUNG GEGENÜBER STEIGROHRSEITE GEPUNK. L-R	GUIDANCE OPPOSITE ASCEND: PIPE POINT WELDED L-R	GUIDAGE EN FACE DE TUYAU ASCEND. COTE EN POINT.G-D
10	8132185-02	FÜHRUNG STEIGROHRSEITE GEPUNKTET R-L	GUIDANCE ASCENDING PIPE POINT WELDED R-L	GUIDAGE TUYAU ASCENDANT COTE EN POINTILLES D-G
11	8132186-02	FÜHRUNG GEGENÜBER STEIGROHRSEITE GEPUNKTET R-L	GUIDANCE OPPOSITE ASCEND. PIPE POINT WELDED R-L	GUIDAGE EN FACE DE TUYAU ASCEND. COTE EN POINT.D-G
12	8100252	BEFESTIGUNG F. OBERES WS	FIXATION FOR UPPER WASH SYSTEM	FIXATION P. SYST.DE LAV. SUPERIEUR
13	8100291	STEIGROHRVERSCHLUSS MIT SCHEIBE	CLOSING OF ASCENDING TUBE WITH WASHER COMPL:	FERMETURE DU TUYAU ASCENDANT AVEC RONDELLE

POS. 2.2 STEIGROHR 1,7/2,2 KW



POS. 2.2 ASCENDING PIPE 1,7/2,2 KW

POS. 2.2 TUYAU ASCENDANT 1,7/2,2 KW

POS.	IDENT.-NR. IDENT.-NO.	BEZEICHNUNG	DESIGNATION	DESIGNATION
------	--------------------------	-------------	-------------	-------------

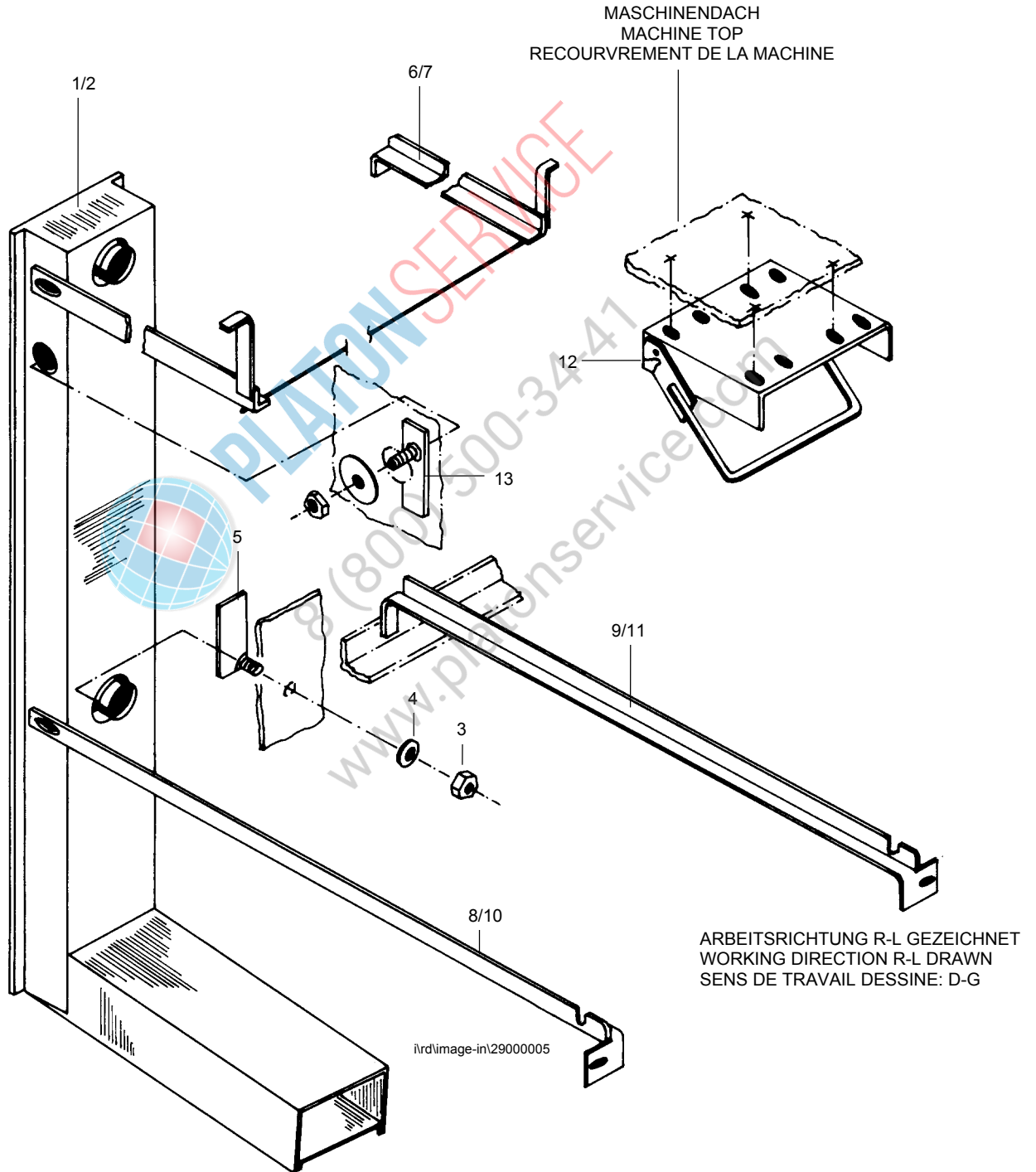

POS. 2.3 WASCHSYSTEM 1,7/2,2 KW



POS. 2.3 WASH SYSTEM 1,7/2,2 KW

POS. 2.3 SYSTEME DE LAVAGE 1,7/2,2 KW

POS.	IDENT.-NR. IDENT.-NO.	BEZEICHNUNG	DESIGNATION	DESIGNATION
1	8132617	WASCHSYSTEM OBEN L-R OHNE KAPPEN	WASH SYSTEM UPPER WITHOUT CAPS L-R	SYSTEME DE LAVAGE SUPER. SANS CAPUCHON G-D
2	8132618	WASCHSYSTEM OBEN R-L OHNE KAPPEN	WASH SYSTEM UPPER WITHOUT CAPS R-L	SYSTEME DE LAVAGE SUPER. SANS CAPUCHON D-G
3	8132621	WASCHSYSTEM UNTEN L-R OHNE KAPPEN	WASH SYSTEM BELOW WITHOUT CAPS L-R	SYSTEME DE LAVAGE INFER. 2,2 KW SANS CAPUCHON G-D
4	8132622	WASCHSYSTEM UNTEN R-L OHNE KAPPEN	WASH SYSTEM BELOW WITHOUT CAPS R-L	SYSTEME DE LAVAGE INFER. SANS CAPUCHON D-G
5	0640422	VERSCHLUSSKAPPE K393	CAP K393	CAPUCHON K393
6	0408226	GUMMIDICHTUNG EPDM D37,3X28	RUBBER SEALING EPDM D37,3X28	JOINT AEN MATIERE PLASTIQUE EPDM D37,3X28

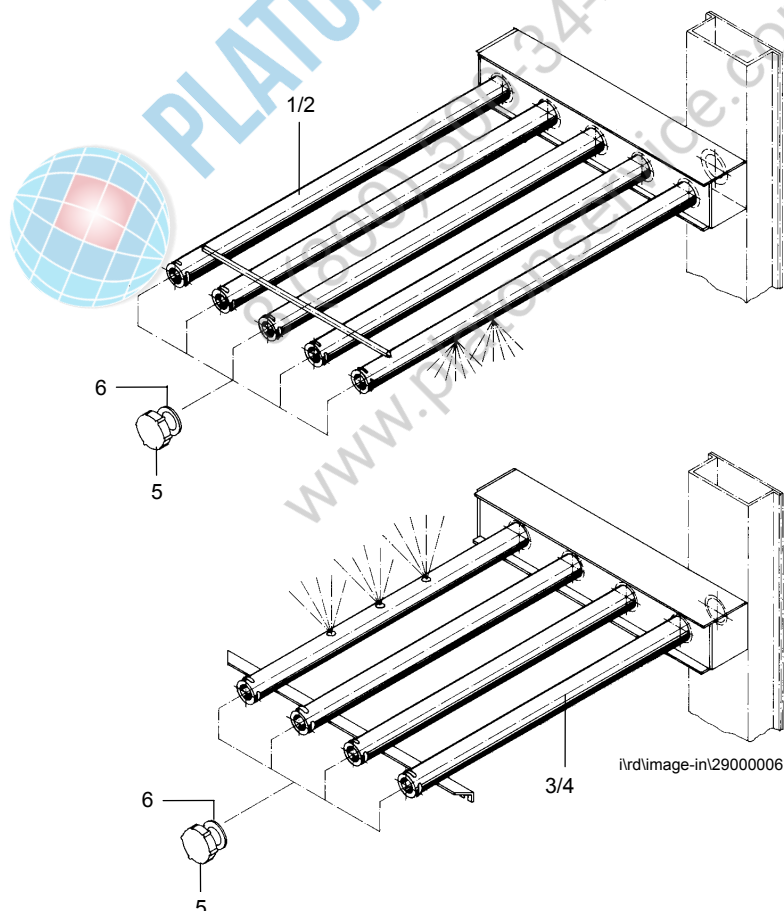

POS. 2.4 SEITLICHES WASCHSYSTEM



POS. 2.4 LATERAL WASH SYSTEM

POS. 2.4 SYSTEME DE LAVAGE LATERAL

POS.	IDENT.-NR. IDENT.-NO.	BEZEICHNUNG	DESIGNATION	DESIGNATION
1	8130702	SEITLICHES WASCHSYSTEM BAUGRUPPE <u>FÜR ARBEITSRICHTUNG R-L</u>	LATERAL WASH SYSTEM COMPL 2 X 4 NOZZLES <u>FOR WORKING DIRECTION R-L</u>	SYSTEME DE LAVAGE LATERAL COMPL. 2 X 4 GICLEURS <u>POUR SENS DE TRAVAIL D-G</u>
2	8132644	SEITL, WASCHARM M. KAPPE K 393 D=33,7*1*318 R-L	LATERAL WASH ARM WITH CAP K 393 D=33,7*1*318 R-L	BRAS DE LAVAGE AVEC CAPUCHON K 393 D=33,7*1*318 D-G
3	8132643	SEITL, WASCHARM M. KAPPE K 393 D=33,7*1*318 R-L <u>FÜR ARBEITSRICHTUNG L-R</u>	LATERAL WASH ARM WITH CAP K 393 D=33,7*1*318 R-L <u>FOR WORKING DIRECTION L-R</u>	BRAS DE LAVAGE AVEC CAPUCHON K 393 D=33,7*1*318 D-G <u>POUR SENS DE TRAVAIL G-</u>
4	8132642	SEITL, WASCHARM M. KAPPE K 393 D=33,7*1*318 L-R	LATERAL WASH ARM WITH CAP K 393 D=33,7*1*318 L-R	BRAS DE LAVAGE AVEC CAPUCHON K 393 D=33,7*1*318 G-D
5	8132641	SEITL, WASCHARM M. KAPPE K 393 D=33,7*1*318 L-R K 393	LATERAL WASH ARM WITH CAP D=33,7*1*318 L-R	BRAS DE LAVAGE AVEC CAPUCHON K 393 D=33,7*1*318 G-D
6		GUMMIDICHTUNG	RUBBER SEALING	JOINT AEN MATIERE PLASTIQUE
7	0620292	VERSCHLUSSKAPPE K292	CLOSING CAP K292	CAPUCHON K292
8	8102042	VERSCHLUSSKAPPE D=34,2X1,5 D=42X14 4301	CLOSING CAP 1" CRNI D34.2 X 1.5 MM	CAPUCHON 1" CRNI D34.2 X 1.5 MM
9	0650010	TÜLLE 1532 GUMMI	RUBBER BUSHING	DOUILLE EN CAOUTCHOUC
10	8100191	VERTEILERBAJONETT KOMPL. EINBAUFERTIG	DISTRIBUTING BAYONET COMPL. READY FOR INST.	BAIONNETTE DISTRIBUTEUR COMPL. PRET A ETRE MONTE
11	8130540	VERTEILERROHR KOMPLETT BAUGRUPPE	DISTRIBUTING PIPE COMPL. READY FOR INSTALLATION	TUYAU-DISTRIBUTEUR COMPL. PRET A ETRE INSTALLE
12	0302000	SECHSKANTSCHRAUBE DIN 933 M 6 X 10 MM, W.-NR. 1.4301	HEXAGON SCREW M 6X10 4301,DIN 933	VIS A 6 PANS M 6X10 4301,DIN 933
13	0337001	SECHSKANTMUTTERN SELBST- SICHERND 4401 M5 DIN 985	HEXAGON NUT SELFFIXING M5 4401 DIN 985	ECROU A SIX PANS M5 4401 DIN 985
14	0321015	SCHAFTSCHRAUBE DIN 427 M6 X 15 MM W.-NR. 1.4301	SCREW M 6X15,DIN 427, 4301	VIS M 6X15,DIN 427,4301
15	0340010	U-SCHEIBE 1.4301 6,3X16X1,5 MM	WASHER 4301 16 X 6,3 X 1,5 MM	RONDELLE 16X6.3X1,5MM 4301

POS. 2.4 SEITLICHES WASCHSYSTEM



POS. 2.4 LATERAL WASH SYSTEM

POS. 2.4 SYSTEME DE LAVAGE LATERAL

POS.	IDENT.-NR. IDENT.-NO.	BEZEICHNUNG	DESIGNATION	DESIGNATION
------	--------------------------	-------------	-------------	-------------

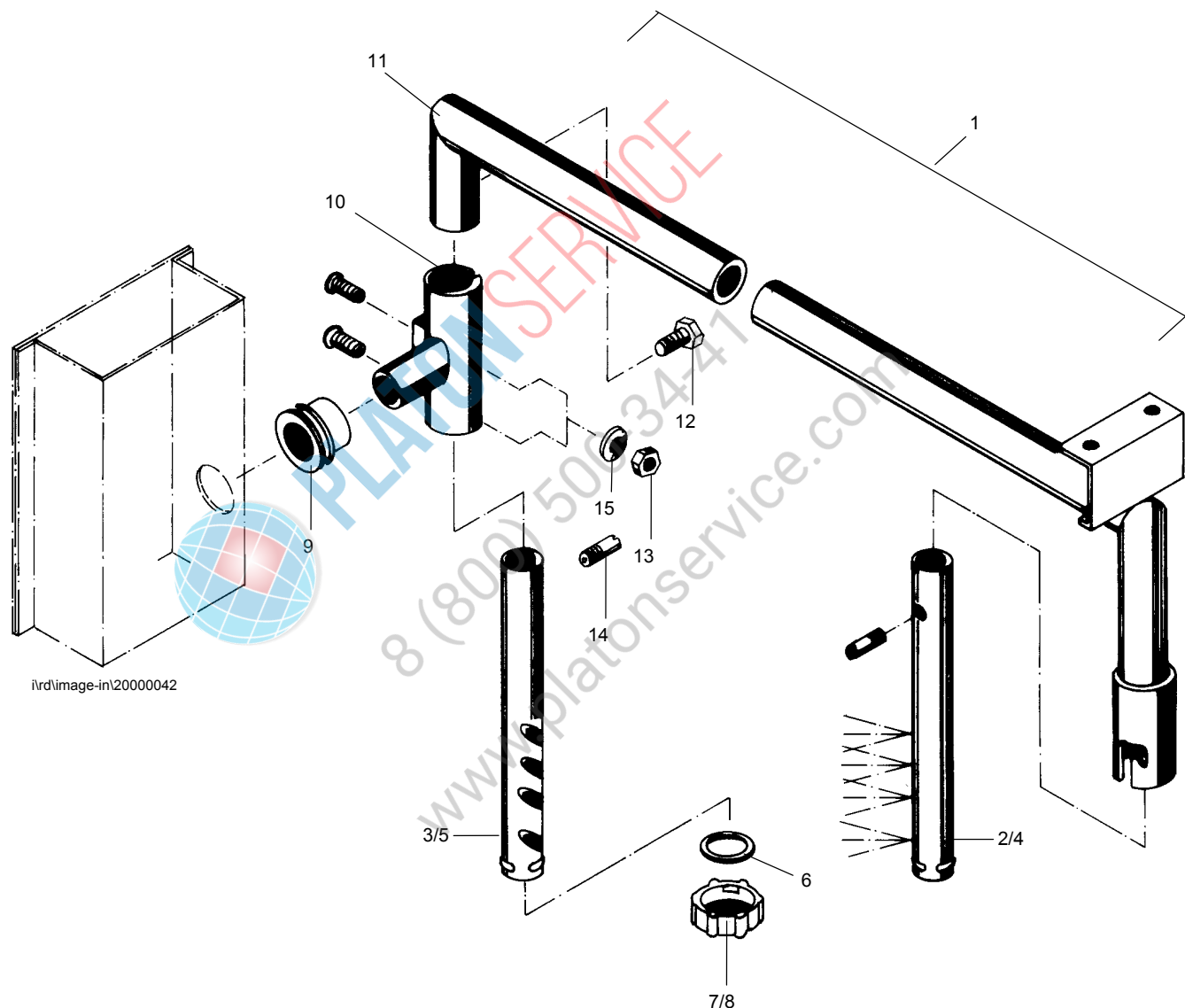

ird\image-in\20000042

PLATON SERVICE
8 (800) 506 34 47
www.platonservice.com

POS. 3.1 WASCHPUMPE 2,2 KW CRNI, 50 HZ



POS. 3.1 WASH PUMP 2,2 KW CRNI, 50 HZ

POS. 3.1 POMPE DE LAVAGE 2,2 KW CRNI, 50 HZ

POS.	IDENT.-NR. IDENT.-NO.	BEZEICHNUNG	DESIGNATION	DESIGNATION
1	0501038	MOTOR PF100L/2P-11 2,2 KW 220-240/380-415 V	PUMP MOTOR PF100L/2P-11 2,2 KW 220-240/380-415 V	MOTEUR DE POMPE PF100L/2P -11 2,2KW220-240/380-415V
2	0335015	SKT.-MUTTER M 8 A2 DIN 934	HEXAGON NUT M 8 4301 DIN 934	ECROU A 6 PANS M 8 4301 DIN 934
3	0340006	U-SCHEIBE MS. VERN. 8,4 X 18 X 2 MM	WASHER BRASS NICKED 8,4 X 18 X 2 MM	RONDELLE 8,4 X 18 X 2 EN LAITON NICKELE
4	0620333	MOTORTRAEGER K 331	MOTOR SUPPORT K 331	SUPPORT DE MOTEUR
5	8101063	FLANSCH MIT DISTANZBOLZEN Ø=150	FLANGE WITH DISTANCE BOLT	FLASQUE P. SUPPORT DE PAN
6	8100824	PUMPENBODEN KOMPL. 2,2 KW GESCHWEISST	PUMP BASE 2,2 KW CPL.	FOND DE POMPE 2,2 KW CPL.
7	0403009	GLEITR.-MANSCHETTE WINKEL 30 X 40 X 7 MM 480000008	COLLAR PERBUNAN 30X40X7 480 000 008	MANCHETTE PEBUNAN 30X40X7,480 000 008
8	0403010	GLEITRING KERAMIK 25,9 X 38 X 8 MM	SLIDING SEAL CERAMICS 25 X 38 8 MM	JOINT AXIAL CERAMIQUE 25 X 38 X 8 MM
9	0403003	GLEITRINGDICHTUNG VITON 25 X 44 X 20 MM	SLIDING SEAL 25 X 44 X 20 MM	JOINT AXIAL 25 X 44 X 20 MM
10	0340010	U-SCHEIBE 1.4301 6,3X16X1,5 MM	WASHER 4301 16 X 6,3 X 1,5 MM	RONDELLE 16 X 6.3 X 1,5MM 4301
11	0302000	SKT.-SCHRAUBE M 6X10 A2 DIN 933	HEXAGON SCREW M 6X10 4301,DIN 933	VIS A 6 PANS M 6X10 4301,DIN 933
12	8100131	U-SCHEIBE D38XD24,1X1	SUPPORT DISC D38XD24,1X1	RONDELLE D38XD24,1X1
13	8102037	BUCHSE 2,2 KW-PUMPE 4301 D=33X55	BUSHING 2,2 KW PUMP 4305 D=33X50	DOUILLE 2,2 KW POMPE 4305 D=33X50
14	0550046	50 HZ PUMPENRAD SP75 165023 V2A 120MM F.PUMPE 2,2KW 50HZ	50 HZ IMPELLER SP 75 V2A 120 MM FOR PUMP 2,2KW 50HZ	50 HZ ROUE DE POMPE SP75 V2A 120MM POMPE 2,2KW 50HZ
	8101620	60 HZ PUMPENRAD 4301 D=120X49	60 HZ IMPELLER 4301 D=120X49	60 HZ ROUE DE POMPE 4301 D=120X49
15	8102036	SKT.-MUTTER M30X1,5 4305 SW41X7	HEXAGON-NUT M30X1,5 4301 SW41X7	ECROU A 6 PANS M30X1,5 4301 SW41X7
16	8100251	U-SCHEIBE D=34X7X2; 4301	FRONT DISC D=34X7X2; 4301	RONDELLE D=34X7X2 4301
17	0302001	SKT.-SCHRAUBE M 6X15 A2	HEXAGON SCREW M6 X 15,	VIS A 6 PANS M 6 X 15,
18	8100823	PUMPENDECKEL 2,2 KW 344,5X281,25X140,25	PUMP LID 2,2 KW 344,5X281,25X140,25	COUVERCLE DE POMPE 2,2 KW 344,5X281,25X140,25
19	0302043	SKT.-SCHRAUBE M 5X10 A2 DIN 933	HEXAGON SCREW M5X10, DIN 933,4301	VIS A 6 PANS M5X10, DIN 933, 4301
20	0337001	SKT.-MUTTER M 5 A4 SELBSTSICH. DIN 985	HEXAGON NUT SELFFIXING M5 4401 DIN 985	ECROU A SIX PANS M5 4401 DIN

POS. 3.1 WASCHPUMPE 2,2 KW CRNI, 50 HZ



POS. 3.1 WASH PUMP 2,2 KW CRNI, 50 HZ

POS. 3.1 POMPE DE LAVAGE 2,2 KW CRNI, 50 HZ

POS.	IDENT.-NR. IDENT.-NO.	BEZEICHNUNG	DESIGNATION	DESIGNATION
------	--------------------------	-------------	-------------	-------------

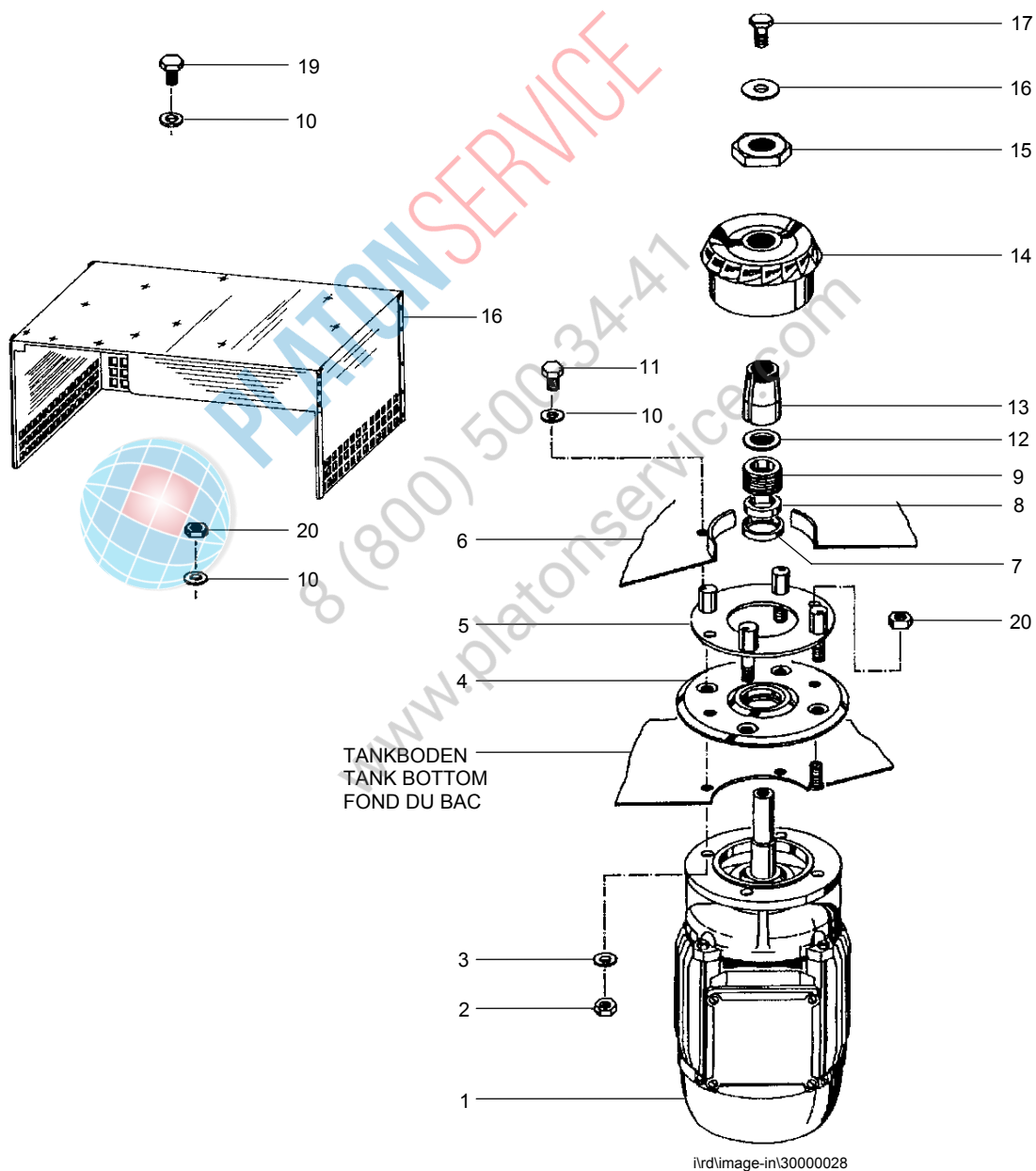

POS. 4.1 PUMPENKLARSPÜLUNG



POS. 4.1 PUMP FINAL RINSE

POS. 4.1 RINCAGE FINAL A POMPE

POS.	IDENT.-NR. IDENT.-NO.	BEZEICHNUNG	DESIGNATION	DESIGNATION
1	0501088	PUMPE 1276 0,55KW 220/380 240/415V 60HZ DREHSTROM	FINAL RINSE PUMP 0,55 KW TYP 3377, 2.750 RPM, COMP	POMPES DE LAVAGE 0,55 KW TYPE 377 2750 TR/MIN. COM
2	0501105	LAGERSCHILD 0,55KW 3878/1 M. PUMPENDECKEL FIR	END SHIELD 0,55 KW WITH LID FIR 38 78/1	FLASQUE AVEC COUVERCLE DE POMPE 0,55 KW FIR 38 78/1
3	0501094	PUMPENGEHÄUSEDICHTUNG GEH 3581 F. PUMPE 0,55 KW	PACKING FOR PUMP HOUSING GEH 3581 FIR 0,55 KW	GARNITURE ETANCHE DE CORPS DE POMPE FIR .55 KW
4	0501093	GEGENRING 13268 112411 FÜR PUMPE 0,55 KW	COUNTER RING 0,55 KW FIR 13268	BAGUE CONTRE-APPUI FIR 13268
5	0501162	GLEITRINGDICHTUNG FUER PUMPE 1276	SLIDING SEAL FOR PUMP 1276	JOINT AXIAL POUR POMPE 1276
6	0501081	PUMPENRAD D=75 MM RYTON F. PUMPE 1276 (0501088)	PUMP WHEEL D=75 MM RYTON F. PUMP 1276 (0501088)	ROUE DE POMPE D=75 MM RYTON POUR POMPE 1276 (0501088)
7	0340026	U-SCHEIBEN MS DIN 134 5,3 X 12 X 1 MM	SUPPORT DISC MS DIN 134 5,3 X 12 X 1 MM	RONDELLE MS DIN 134 5,3 X 12 X 1 MM
8	0341002	FEDERRING 127 A 5 MM	SPRING WASHER A 5 DIN 127	RONDELLE-RESSORT A 5 DIN 127
9	0308056	ZYL.KOPFSCHRAUBE MS-VERN. M5 X 15 MM 84	CYLINDER HEAD ACREW M 5X15 DIN 84	VIS A TETE CYLINDRIQUE M 5X15 DIN 84
10	0501091	PUMPENGEHAEUSE GEH 3575 FÜR PUMPE 0,55 KW	PUMP HOUSING GEH 3575 FIR 0,55 KW	CORPS DE POMPE GEH 3575 FIR 0,55 KW
11	0307055	LINSENZYL.SCHRAUBE DIN 85 MS-VERN. M4 X 30	CYLINDER HEAD SCREW M 4 X 30 DIN 85	VIS A TETE CYLINDRIQUE M 4 X 30 DIN 85
12	0337000	SKT.-MUTTER M 4 A4 SELBSTSICH. DIN 985	SAFETY NUT M 4, DIN 985, 4301	ECROU DE SECURITE M 4 DIN 985, 4301
13	0411003	DICHTSCHEIBE KUNSTSTOFF PE M 8	PLASTIC SEAL D=8	JOINT PLASTIQUE D=8
14	8102291	NIPPEL-PU-NS G=3/4" PPH D=40X55	NIPPLE-PU-FINAL RINSE R3/4" PPH D=40X55	NIPPLE-POMPE RINCAGE FINAL R3/4" PPH D=40X55
15	8101229	ANSAUGSIEB-PUMPENNACH- SPÜLUNG	PUMP FINAL RINSE-SIEVE BASKET	FILTRE INOX P. POMPE DE RINCAGE; PARTIE II SUP.
16	0237095	ANSAUGSIEB F. PUMPENNACH- SPÜELUNG 1.4301 434125030	SUCTION SIEVE F. PUMP FINAL RINSE	FILTRE INOX A. MANCHON FILETE P. POMPE RINCAGE
17	8101337	ANSAUGSTUTZEN PU-NS BAUGRUPPE	SUCTION PORT PUMP FINAL RINSE	MANCHON D'ASPIRATION
18	0302006	SKT.-SCHRAUBE M 8X15 A2 DIN 933	HEXAGON SCREW M 8 X 15, DIN 933, 4301	VIS A 6 PANS M 8X15 DIN 933,4301
19	8100295	MOTORKONSOLE 140X119X*56	MOTOR CONSOLE 252 X 140 = 1,25	CONSOLE DE MOTEUR 252 X 140 = 1,25
20	0233046	NORMA-KLEMME 1348030041 32-50 MM 9 MM	HOSE CLAMP 32-50	COLLIER DE TUYAU 32-50

POS. 4.1 PUMPENKLARSPÜLUNG



POS. 4.1 PUMP FINAL RINSE

POS. 4.1 RINCAGE FINAL A POMPE

POS.	IDENT.-NR. IDENT.-NO.	BEZEICHNUNG	DESIGNATION	DESIGNATION
21	8100538	SCHLAUCH PU DRUCKSEITE D = 38 X 4 X 42	HOSE PU, PRESSURE S. D = 38 X 4 X 42	TUYAU D = 38 X 4 X 42
22	0630209	SCHLAUCH GLASKLAR DM35X5 MM PVC	HOSE, TRANSPARENT D=34 I X 55	TUYAU FLEXIBLE TRANS- PARENT D=34 I X 55
23	0212011	UEBERWURFMUTTER MS 2" DIN 1325	SLEEVE NUT MS 2" DIN 1325	ECROU RACCORD MS 2" DIN 1325
24	0293010	GUMMIDICHTUNG 891.340.00.0	RUBBER PACKING 891.340.00	JOINT CAOUCHOUK 891.340.00.0
25	0237008	STANDR.VENT.-MUTTER 9942 2" X 88 MM MS.	NUT. NO. 9942 MS 2" X 88 MM	ECROU NO. 9942 MS 2" X 88 MM
26	0408224	GUMMIDICHTUNG EPDM 78X6 MM	RUBBER PACKING 78X60X2MM	JOINT CAOUCHOUK 78X60X2 MM

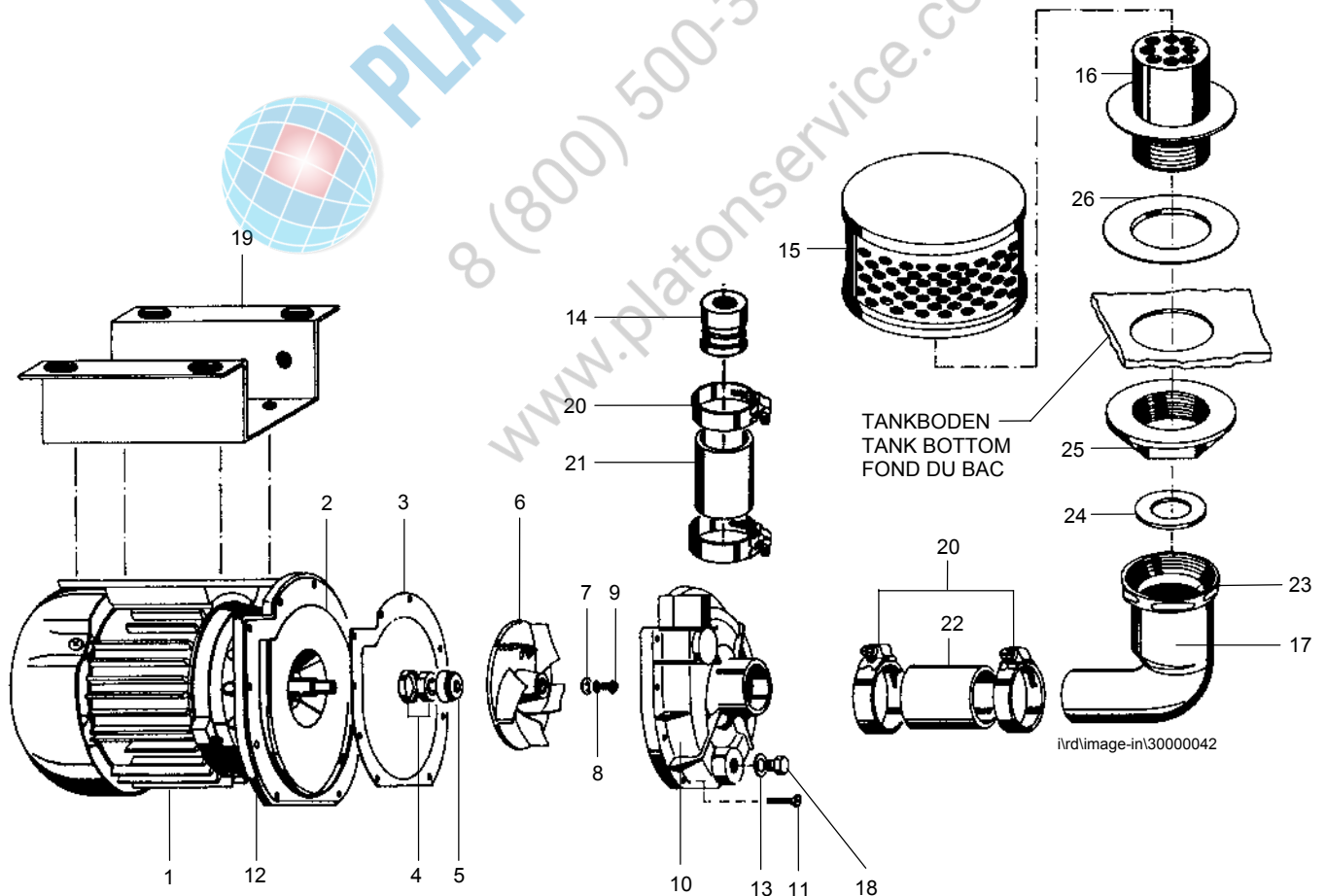

POS. 4.2 PUMPENKLARSPÜLUNG: STEIGROHRE+SPRÜHARME



POS. 4.2 PUMP FINAL RINSING: ASCENDING TUBE+SPRAY ARMS

POS. 4.2 RINCAGE FINAL A POMPE: TUYAU ASCENDANT+BRAS DE LAVAGE

POS.	IDENT.-NR. IDENT.-NO.	BEZEICHNUNG	DESIGNATION	DESIGNATION
1	8132122-01	STEIGLEITUNG P-NSP L-R SCHWEIßTEIL	ASCENDING PIPE WELDING PART	TUYAU ASCENDANT PIECE A SUDER
2	8132122-02	STEIGLEITUNG P-NSP R-L SCHWEIßTEIL	ASCENDING PIPE WELDING PART	TUYAU ASCENDANT PIECE A SUDER
3	0431052	SICHERUNGSRING B 230-34 20MM F.PU-NACHSPÜLARM	SAFETY RING B230-34 20 MM	BAGUE DE SECURITE B230-34.00.07.4
4	0401011	O-RING EPDM 12X1,5 MM	WASHER D = 12 X 1,5	BAGUE O D=12 X 1,5
5	0321010	SCHAFTSCHRAUBE DIN 427 M6X20 MM 1.4301	HEADLESS SREW DIN 427 M6X20 MM 1.4301	VIS SANS TETE DIN 427 M6X20 MM 1.4301
6	0472035	DÜSE 1/16" NPT 8020 SS ELP V2A 2,0	NOZZLE 1/16" NPT 8020 SS ELP V2A 2,0	GICLEUR 1/6" NPT 8020 SS ELP V2A 2,0
7	8130457	PUMPEN-NACHSPÜLARM UNTEN EINBAUFERTIG	LOWER POWER FINAL RINSE ARM	BRAS DE RINCAGE FINAL A POMPE INFER.K200-34.02.11
8	8130456	PUMPEN-NACHSPÜLARM OBEN EINBAUF.	UPPER POWER FINAL RINSE ARM K200-34.02.10	BRAS DE RINCAGE FINAL A POMPE SUP. K200-34.02.10
9	8104009	MUTTER,BLECH R 3/4" 1.4301 DRM=50	TANK BORE-HOLE B 230 KN-72	PERCAGE ENTRE LES BACS B 230 KN-72
10	8660097	SKT-MUTTER R=3/4" SW32X8 MS	HEXAGON NUT 3/4" BRASS SW 32X12 N11-13.5	ECROU A 6 PANS 3/4"LAITON SW 32X12 N11-13.5



8 (800) 500-34-41
www.platonservice.com

POS. 4.2 PUMPENKLARSPÜLUNG: STEIGROHRE+SPRÜHARME



POS. 4.2 PUMP FINAL RINSING: ASCENDING TUBE+SPRAY ARMS

POS. 4.2 RINCAGE FINAL A POMPE: TUYAU ASCENDANT+BRAS DE LAVAGE

POS.	IDENT.-NR. IDENT.-NO.	BEZEICHNUNG	DESIGNATION	DESIGNATION
------	--------------------------	-------------	-------------	-------------

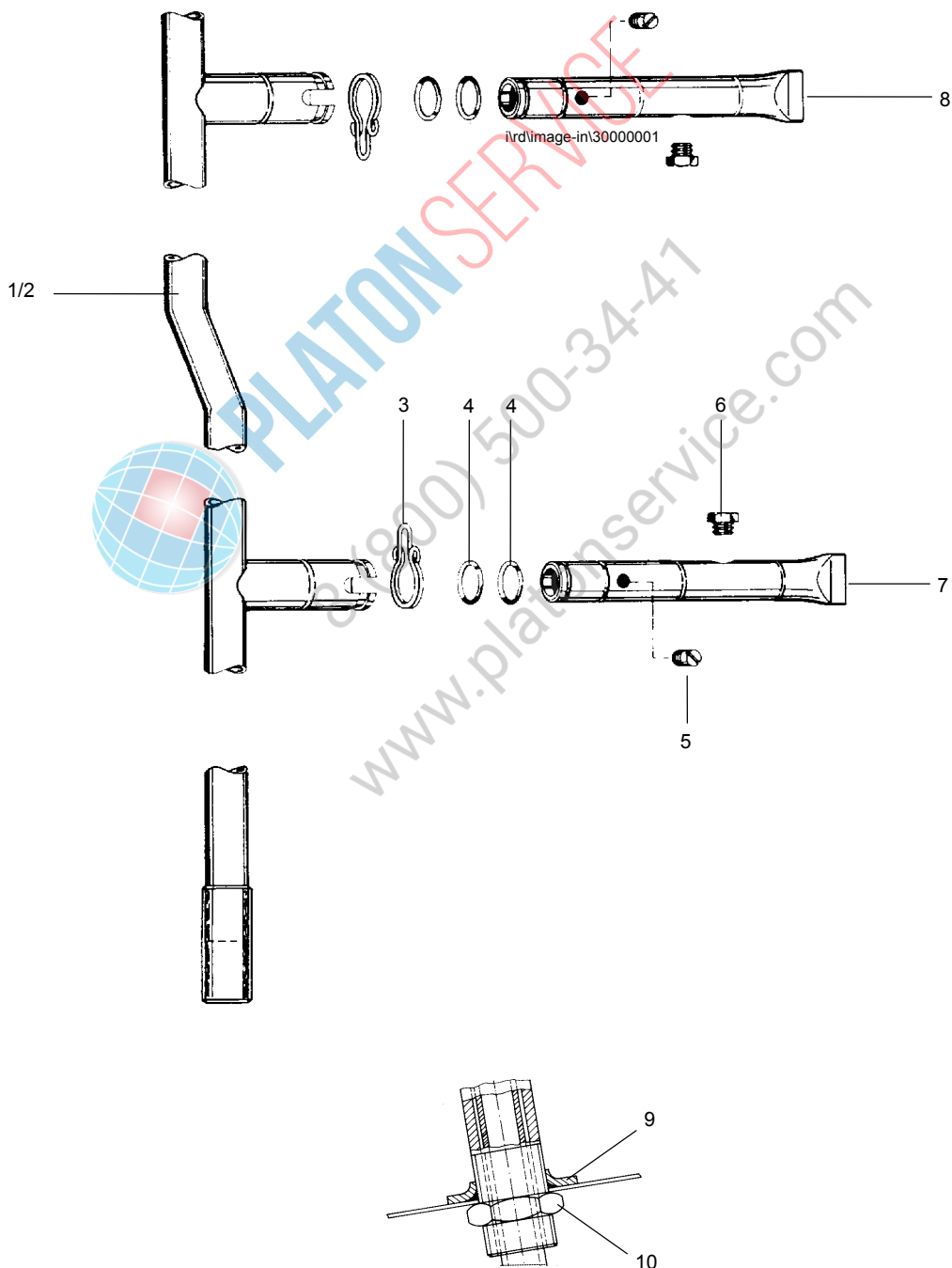

POS. 5.1 FRISCHWASSERKLARSPÜLUNG: STEIGROHRE+SPRÜHARME**POS. 5.1 FRESH WATER RINSING: ASCENDING TUBE+SPRAY ARMS****POS. 5.1 RINCAGE FINAL A EAU CLAIRE: TUYAU ASCENDANT+BRAS DE LAVAGE**

POS.	TEILE-NR. IDENT-NO.	BENENNUNG	DESIGNATION	DESIGNATION
1	8132179	STEIGLEITUNG F-NSP L-R SCHWEIßTEIL	ASCENDING PIPE WELDING PART	TUYAU ASCENDANT PIECE A SUDER
2	8132181	STEIGLEITUNG F-NSP R-L SCHWEIßTEIL	ASCENDING PIPE WELDING PART	TUYAU ASCENDANT PIECE A SUDER
3	0431050	SICHERUNGSRING B 230-31 16MM F.FRISCHW.NACHSP.ARM	SAFETY RING FOR FINAL RINSE FIXING	BAGUE DE SECURITE POUR FIXATION DE RINCAGE FINAL
4	8130008	NSP-ARM OBEN,OHNE DÜSEN 1.4301 D=16*2-375	UPPER FINAL RINSE ARM K200-33.01.10	BRAS DE RINCAGE FINAL SUPERIEUR K200-33.01.10
5	8130009	NSP-ARM UNTEN,OHNE DÜSEN 1.4301 D=16*2-405	LOWER FINAL RINSE ARM K200-33.01.11	BRAS DE RINCAGE FINAL INFERIEUR K200-33.01.11
6	0401011	O-RING EPDM/EP6702-1 12 X 1,5 MM	WASHER D = 12 X 1,5	BAGUE O D=12 X 1,5
7	0321015	SCHAFTSCHRAUBE DIN 427 M6 X 15 MM W.-NR. 1.4301	SCREW M 6X15,DIN 427, 4301	VIS M 6X15,DIN 427,4301
8	0472031	DÜSE 1/16" NPT-8005 LP/SS 0,5	FINAL RINSE NOZZLE CRNI W. THREAD 1/16" NPT/BLUE	GICLEUR DE RINCAGE FINAL CRNI AVEC FILET 1/16" NPT
9	8104009	MUTTER,BLECH R 3/4" 1.4301 DRM=50	TANK BORE-HOLE B 230 KN-72	PERCAGE ENTRE LES BACS B 230 KN-72
10	8660097	SKT-MUTTER R=3/4" SW32X8 MS	HEXAGON NUT 3/4" BRASS SW 32X12 N11-13.5	ECROU A 6 PANS 3/4"LAITON SW 32X12 N11-13.5



8 (800) 300-447
www.platonservice.com

POS. 5.1 FRISCHWASSERKLARSPÜLUNG: STEIGROHRE+SPRÜHARME



POS. 5.1 FRESH WATER RINSING: ASCENDING TUBE+SPRAY ARMS

POS. 5.1 RINCAGE FINAL A EAU CLAIRE: TUYAU ASCENDANT+BRAS DE LAVAGE

POS.	TEILE-NR. IDENT-NO.	BENENNUNG	DESIGNATION	DESIGNATION
------	------------------------	-----------	-------------	-------------

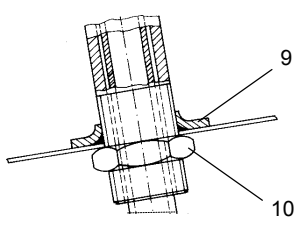
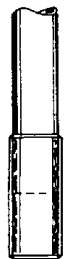
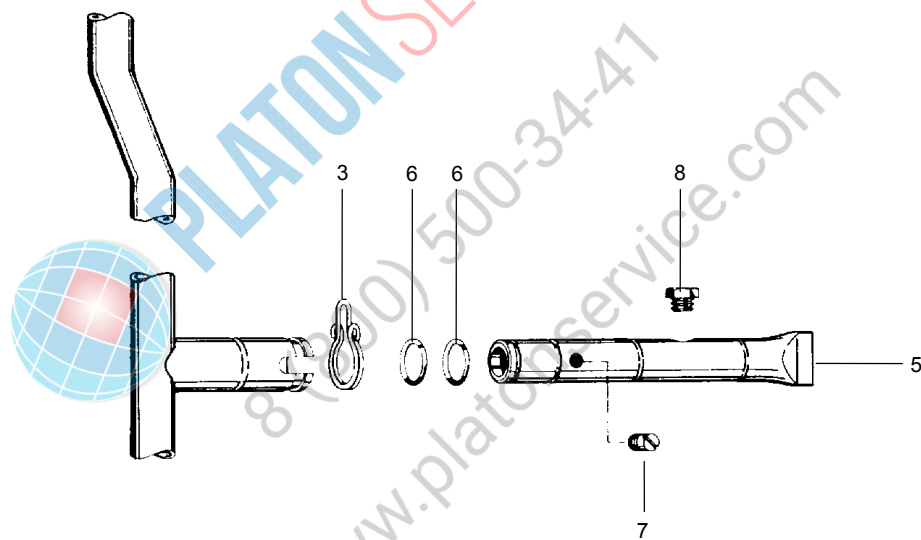
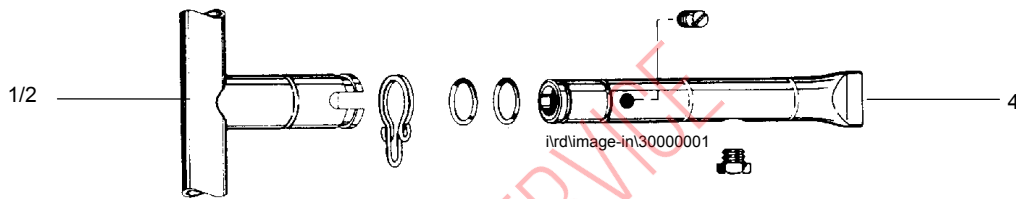

POS. 6.1 RÜCKSAUGVERHINDERUNGSVORRICHTUNG



POS. 6.1 BACKFLOW PREVENTER DEVICE

POS. 6.1 DISPOSITIF ANTI RETOUR

POS.	IDENT.-NR. IDENT.-NO.	BEZEICHNUNG	DESIGNATION	DESIGNATION
1	8001089	RÜCKSAUGEVERH.VORRICHTUNG ÜBERLAUF M. WINKEL KPL.	BACKFLOW PREVENTER DEVICE CPL.	DISPOSITIF ANTI-RETOUR CPL.
2	0620235	DÜSENUNTERSATZ K235	NOZZLE SUPPORT K 235	SUPPORT DE GICLEURS K 235
3	0650010	TUELLE 1532 GUMMI	RUBBER BUSHING	DOUILLE EN CAOUTCHOUC
4	0233037	NORMA-KLEMME 16-27 MM	HOSE CLAMP 16-27 MM	COLLIER DE TUYAU 16-27 MM

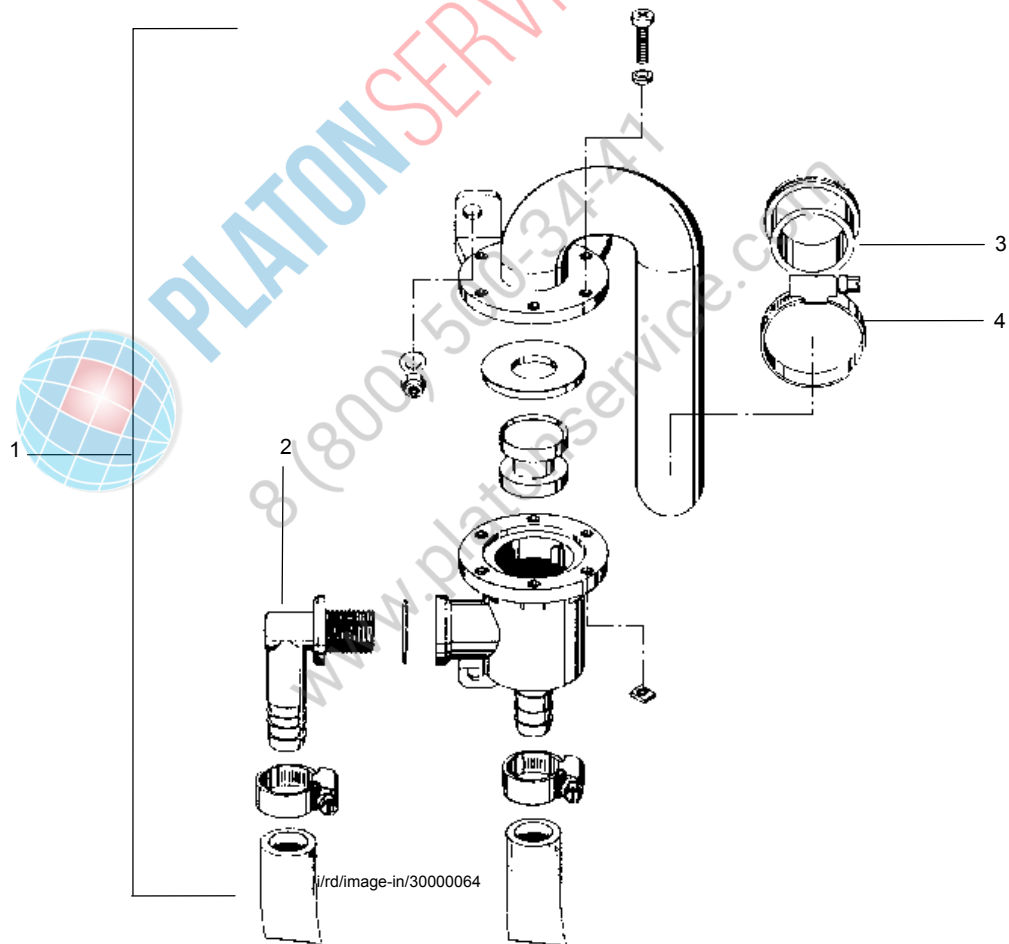

POS. 6.2 SCHMUTZFÄNGER



POS. 6.2 DIRT TRAP

POS. 6.2 COLLECTEUR DE BOUE

POS.	IDENT.-NR. IDENT.-NO.	BEZEICHNUNG	DESIGNATION	DESIGNATION
1	0225002	SCHMUTZFAENGER MS 1/2 ZOLL	DIRT TRAP MS 1/2"	COLLECTEUR DE BOUE MS 1/2"
2	0225007	SCHMUTZFÄNGER V2A 3/4 ZOLL	DIRT TRAP V2A 3/4" 3/4"	COLLECTEUR DE BOUE V2A 3/4"
3	0225008	SCHMUTZFÄNGER RG 3/4 ZOLL	DIRT TRAP 3/4" RED BRASS 3/4"	COLLECTEUR DE BOUE LAITON 3/4"
4	0225003	MUFFE SCHMUTZFÄNGER V2A 1/2 ZOLL	MUFF DIRT TRAP V2A 1/2"	MANCHON COLLECTEUR DE BOUE V2A 1/2"
5	0225009	SCHMUTZFÄNGERSIEB V2A 3/4 ZOLL	DIRT TRAP SIEVE V2A 3/4"	FILTRE A COLLECTEUR DE BOUE V2A 3/4"
6	0225004	SCHMUTZFÄNGERSIEB V2A 1/2 ZOLL	DIRT TRAP SIEVE V2A 3/4" 3/4"	FILTRE-COLLECTEUR V2A DE BOUE

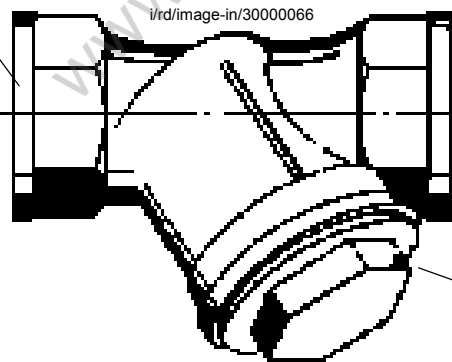

POS. 6.3 MAGNETVENTIL FÜR KLARSPÜLUNG



POS. 6.3 SOLENOID VALVE FOR FINAL RINSE

POS. 6.3 ELECTROVANNE POUR RINCAGE FINAL

POS.	IDENT.-NR. IDENT.-NO.	BEZEICHNUNG	DESIGNATION	DESIGNATION
1	0113220	MAGNETVENTILKÖRPER BIS 60°C, DN15,R 3/4"	BODY OF SOLENOID VALVE 60°C, DN15,R 3/4"	CORPS D'ELECTROVANNE 60°C, DN15,R 3/4"
2	0113096	MAGNETV.-GERÄTESTECKER GM 205 GR 990 0336-01-000	APPLIANCE PLUG GM 209 GR 990 0336-01-000	SOCLE CONNECTEUR GM 209 GR 990 0-336-01.000
3	0113256	MAGNETSPULE MSRA 0024- 01.00 V220-039 3/4"	COIL F. SOL/VALVE 3/4 " 220 V / 50 HZ; A & K	BOBINE V220-039 220 V 3/4"
4	0113224	MAGNETVENTILFEDER FUER 0113200/0113210	SPRING F. SOL/VALVES P/NO. 0113200/0113210	RESSORT D'ELECTROVANNE
5	0113004	MAGNETVENTILFILTERSIEB WR 32-29KUNSTSTOFF	LARGE FILTER F. SOLENOID VALVE PLASTICS, WR32-29	FILTRE GRAND POUR ELECTRO VANNE,PLASTIQUE WR 32-29
6	0217433	GUMMIDICHTUNG 17 X 24 X 2 MM	RUBBER PACKING 17 X 24 X 2 MM	JOINT CAOUTCHOUC 17 X 24 X 2 MM

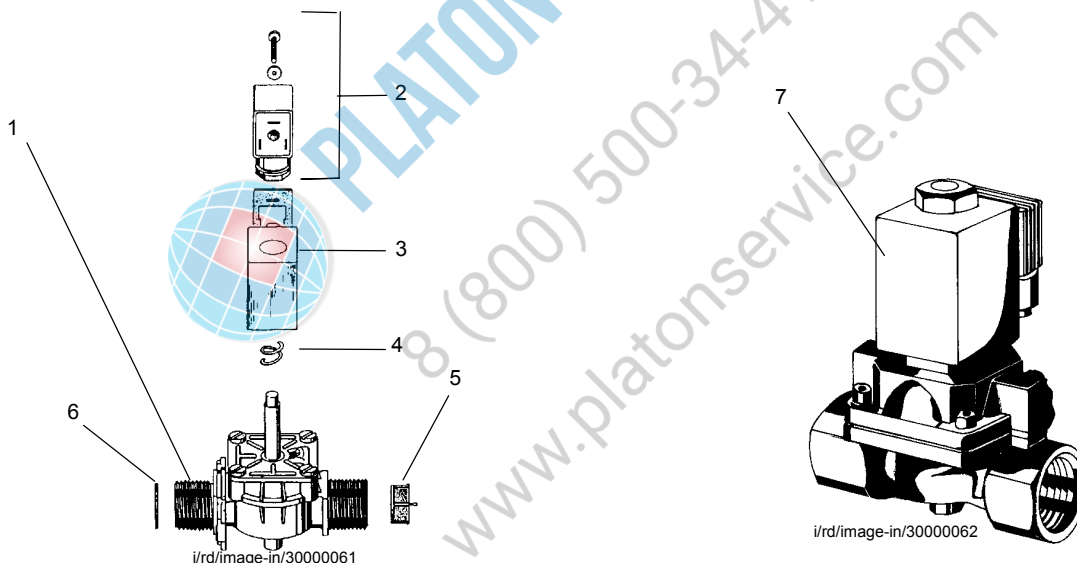

**FÜR TEMPERATUREN
ÜBER 60°C**

WAHLWEISE

7 0113100 MAGNETVENTIL 407-A-20,0-
G-MS 3/4-220/50-F-000
RECHTSBÜNDIG

ODER

0113034 MAGNETVENTIL 213 SVS 21 E
13-36T 3/4" 120766322011
RECHTSBÜNDIG

**FOR TEMPERATURES
ABOVE 60°C**

OPTIONALLY

SOLENOID VALVE 407-A-20,0
-G-BRASS 3/4-220/50-F-000
RIGHT-ALIGNED

OR

SOLENOID VALVE 213 SVS 21
E 13-36T 3/4"120766322011
RIGHT-ALIGNED

**POUR TEMPERATURES
PLUS DE 60°C**

EN OPTION

ELECTROVANNE 407-A-20,0-
G-LAITON 3/4-220/50-F-000
CADRE A DROITE

OU

ELECTROVANNE 213 SVS 21 E
1336T 3/4" 120766322011
CADRE A DROITE

POS. 6.4 MAGNETVENTIL FÜR FÜLLVENTIL



POS. 6.4 SOLENOID VALVE FOR FILLING VALVE

POS. 6.4 ELECTROVANNE POUR VANNE DE REMPLISSAGE

POS.	IDENT.-NR. IDENT.-NO.	BEZEICHNUNG	DESIGNATION	DESIGNATION
1	0113222	MAGNETVENTIL 220V 50HZ 01-1.017.126-2 O.SPULE	SOLENOID VALVE 220V 50HZ 01-1.017.126-2 W.O. COIL	ELECTROVANNE 220 V, 50 CYCLES 01.1.017.126-2
2	0113096	MAGNETV.-GERÄTESTECKER GM 205 GR 990 0336-01-000	APPLIANCE PLUG GM 209 GR 990 0336-01-000	SOCLE CONNECTEUR GM 209 GR 990 0-336-01.000
3	0113256	MAGNETSPULE MSRA 0024- 01.00 V220-039 3/4"	COIL F. SOL/VALVE 3/4 " 220 V / 50 HZ; A & K	BOBINE V220-039 220 V 3/4"
4	0113224	MAGNETVENTILFEDER FUER 0113200/0113210	SPRING F. SOL/VALVES P/NO. 0113200/0113210	RESSORT D'ELECTROVANNE
5	0113004	MAGNETVENTILFILTERSIEB WR 32-29KUNSTSTOFF	LARGE FILTER F. SOLENOID VALVE PLASTICS, WR32-29	FILTRE GRAND POUR ELECTRO VANNE,PLASTIQUE WR 32-29
6	0217433	GUMMIDICHTUNG 17 X 24 X 2 MM	RUBBER PACKING 17 X 24 X 2 MM	JOINT CAOUTCHOUC 17 X 24 X 2 MM

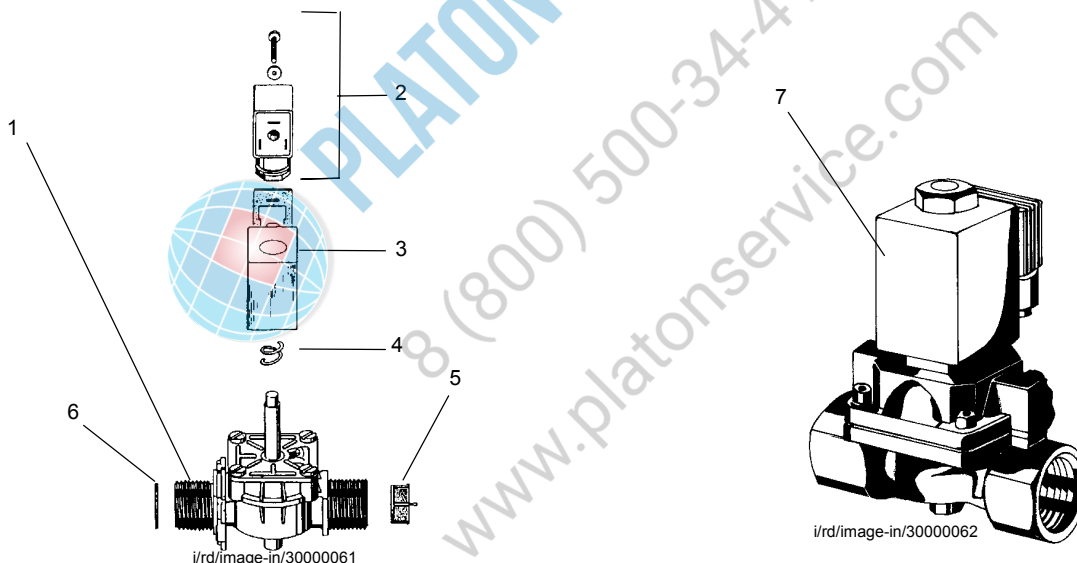

**FÜR TEMPERATUREN
ÜBER 60°C**

**FOR TEMPERATURES
ABOVE 60°C**

**POUR TEMPERATURES
PLUS DE 60°C**

7 0113100
WAHLWEISE
MAGNETVENTIL 407-A-20,0-
G-MS 3/4-220/50-F-000
RECHTSBÜNDIG

OPTIONALLY
SOLENOID VALVE 407-A-20,0
-G-BRASS 3/4-220/50-F-000
RIGHT-ALIGNED

EN OPTION
ELECTROVANNE 407-A-20,0-
G-LAITON 3/4-220/50-F-000
CADRE A DROITE

0113034
ODER
MAGNETVENTIL 213 SVS 21 E
13-36T 3/4" 120766322011
RECHTSBÜNDIG

OR
SOLENOID VALVE 213 SVS 21
E 13-36T 3/4"120766322011
RIGHT-ALIGNED

OU
ELECTROVANNE 213 SVS 21 E
1336T 3/4" 120766322011
CADRE A DROITE

POS. 6.5 ÜBERDRUCKVENTIL



POS. 6.5 STEAM TRAP

POS. 6.5 SEPARATEUR DE VAPEUR

POS.	IDENT.-NR. IDENT.-NO.	BEZEICHNUNG	DESIGNATION	DESIGNATION
1	0232001	SICHERHEITSVENTIL 1/2"	OVER-PRESSURE VALVE 1/2"	SOUPAPE DE SURPRESSION 1/2"
2	0621037	NIPPEL KST. 12/R 1/2"	NIPPLE KST. 12/R 1/2"	NIPPLE KST. 12/R 1/2"
3	0233037	NORMA-KLEMME 1248030020 16-27 MM	HOSE CLAMP MS/4301 20-32	COLLIER DE TUYAU MS/4301 20-32
4	0640012	SCHLAUCH GRAU 1/2" FÜR WASCHMASCHINE	HOSE GREY 1/2" FOR WASHER	TUYAU FLEXIBLE GRIS 1/2" POUR DEGORGEOIR
5	0620162	MUTTER 3/8" K162	HEXAGON NUT HOSTAFORM C 3/8"	ECROU A 6 PANS HOSTAFORM C 3/8"
6	0408003	DICHTRING AFM 34 17 X 24 X 1,5 MM	KLINGERIT PACKING	JOINT KLINGERIT
7	0620235	DÜSENUNTERSATZ GRAU K235	NOZZLE SUPPORT K 235 GRAU	SUPPORT DE GICLEURS K 235

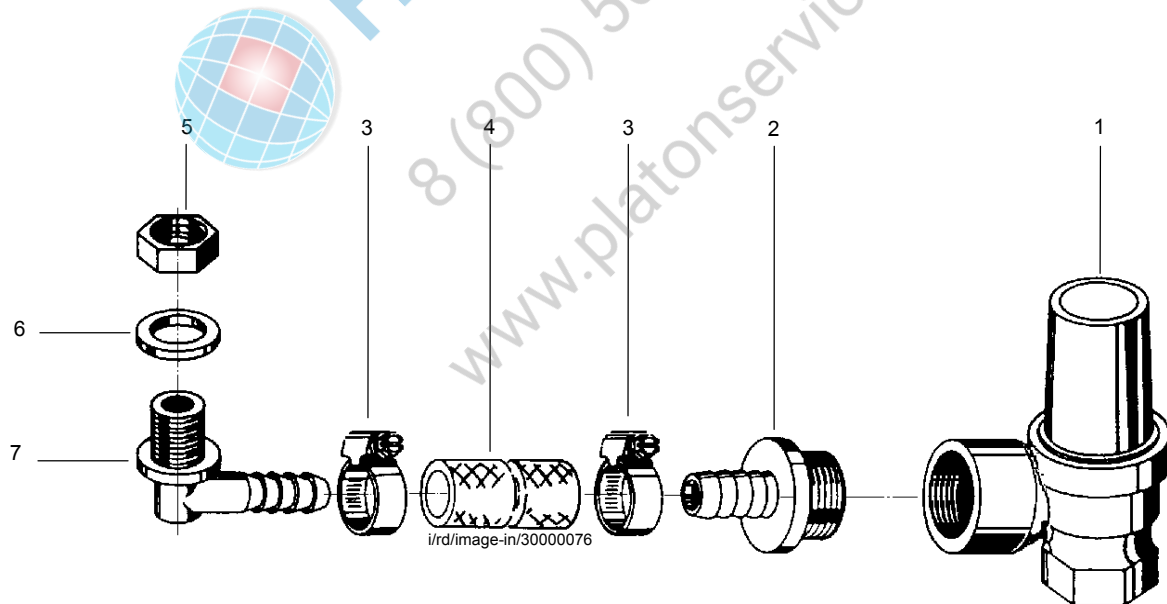

POS. 6.6 DRUCKMINDERER



POS. 6.6 PRESSURE REDUCING VALVE

POS. 6.6 REDUCTEUR DE PRESSION

POS.	IDENT.-NR. IDENT.-NO.	BEZEICHNUNG	DESIGNATION	DESIGNATION
1	0232012	DRUCKMINDERVENTIL 2828 1/2" MS. MIT MANOMETER	PRESSURE REDUCING VALVE 1/2"	REDUCTEUR DE PRESSION 1/2"
2	0232080	DRUCKMINDERVENTIL DMV 750 DN 10 1-9 BAR KOMPLETT	PRESSURE REDUCING VALVE DMV 750; DN 10 1-9 BAR	REDUCTEUR DE PRESSION DMV 750; DN 10 1-9 BAR
3	0232081	DRUCKMINDERVENTIL D06FN-1/2" A	PRESSURE REDUCING VALVE D06FN-1/2" A	REDUCTEUR DE PRESSION D06FN-1/2" A

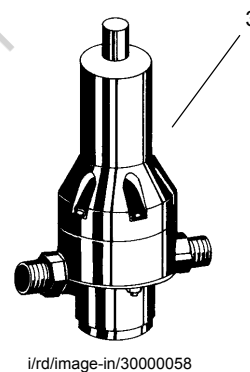
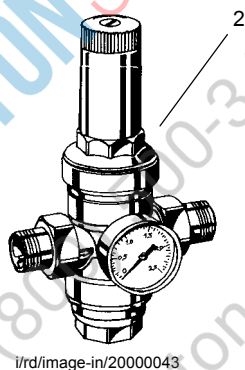
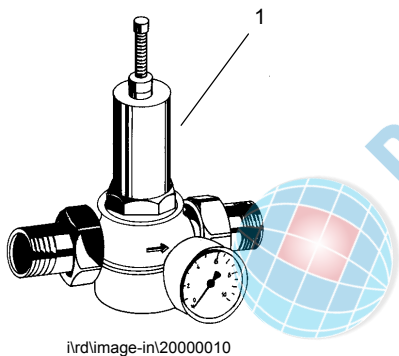

POS. 6.7 DURCHLAUFERHITZER DAMPF



POS. 6.7 BOILER STEAM

POS. 6.7 SURCHAUFFEUR VAPEUR

POS.	IDENT.-NR. IDENT.-NO.	BEZEICHNUNG	DESIGNATION	DESIGNATION
1	8450220	WÄRMETAUSCHER WT7X2/300/108/0,4	HEAT EXCHANGER WT7X2/300/108/0,4	ECHANGEUR DE CHALEUR WT7X2/300/108/0,4
2	8450221	WÄRMETAUSCHER WT7X2/450/108/0,6	HEAT EXCHANGER WT7X2/450/108/0,6	ECHANGEUR DE CHALEUR WT7X2/450/108/0,6
3	8450222	WÄRMETAUSCHER WT7X2/600/108/0,8	HEAT EXCHANGER WT7X2/600/108/0,8	ECHANGEUR DE CHALEUR WT7X2/600/108/0,8
4	8450223	WÄRMETAUSCHER WT7X2/300/150/0,9	HEAT EXCHANGER WT7X2/300/150/0,9	ECHANGEUR DE CHALEUR WT7X2/300/150/0,9
5	8450224	WÄRMETAUSCHER WT7X2/450/150/1,4	HEAT EXCHANGER WT7X2/450/150/1,4	ECHANGEUR DE CHALEUR WT7X2/450/150/1,4
6	8450225	WÄRMETAUSCHER WT7X2/600/150/1,9	HEAT EXCHANGER WT7X2/600/150/1,9	ECHANGEUR DE CHALEUR WT7X2/600/150/1,9
7	8450226	WÄRMETAUSCHER WT7X2/450/200/1,4	HEAT EXCHANGER WT7X2/450/200/1,4	ECHANGEUR DE CHALEUR WT7X2/450/200/1,4
8	8450219	ÜBERWURFMUTTER FÜR WT MS SW 50°G 1 1/4 ' X 30	SWIVEL NUT SW 50°G 1 1/4 ' X 30	ECROU-RACCORD SW 50°G 1 1/4 ' X 30
9	8450218	REDUZIERNIPPEL FÜR WT 1.4301 D=38/3/4G**33 B=16	REDUCTION NIPPLE 1.4301 D=38/3/4G**33 B=16	NIPPLE DE REDUCTION 1.4301 D=38/3/4G**33 B=16
10	0408102	DICHTUNG FLACH 1,6 GYLON FAWN 27X38 MM 3/4"	PACKING FAWN 27X38 MM 3/4"	JOINT FAWN 27X38 MM 3/4"

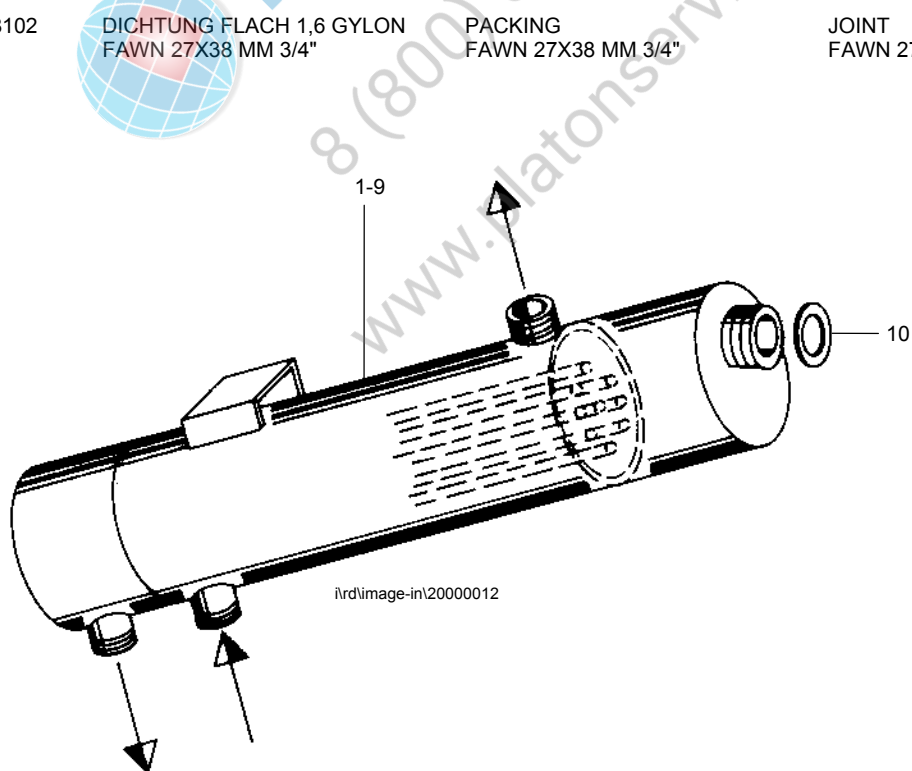

POS. 6.8 DURCHLAUFERHITZER EL.



POS. 6.8 BOILER ELECTRICAL

POS. 6.8 SURCHAUFFEUR ELECTRIQUE

POS.	IDENT.-NR. IDENT.-NO.	BEZEICHNUNG	DESIGNATION	DESIGNATION
1	8101328	DURCHLAUFWASSERERWÄRMER 36 KW 415 V (30 KW 380 V)	BOILER 36 KW 415 V (30 KW 380 V)	SURCHAUFFEUR A 36KW/415V (30 KW 380 V)
2	8101113	MANTEL KPL. FÜR DURCHLAUF- WASSERERWÄRMER	HOUSING COMPL. FOR BOILER	CORPS COMPL. POUR SURCHAUFFEUR
3	0337003	SECHSKANTMUTTER SELBST- SICHERND 4401 M6DIN 985	HEXAGON NUT M 6, CIN 985, 4401	VIS A 6 PANS M 6, DIN 985 4401
4	0340010	U-SCHEIBE 4301 16 X 6,3 X 1,5 MM	WASHER 16 X 6,3 X 1,5 MM 4301	RONDELLE 16 X 6.3 X 1,5MM 4301
5	0302002	SECHSKANTSCHRAUBE DIN 933 M 6 X 20 MM, W.-NR.1.4301	HEXAGON SCREW M 6 X 20 DIN 933, 4301	VIS A 6 PANS M 6 X 20, DIN 933, 4301
6	0162104	GEGENMUTTER METALL PG 21	METAL COUNTERNUT PG 21	CONTRE-ECROU, METALLIQUE PG 21
7	0165111	SCHLAUCHVERSCHRAUBUNG KST KSV 21 ART.NR. 2200210	HOSE SCREWING PLASTICS KSV 21 NO. 2200210	VISSAGE DE TUYAU KSV 21 MAT.PLASTIQUE NO.2200210
8	8101116	SCHUTZABDECKUNG D = 150 X 126	PROTECTION COVER D = 150 X 126	RECOUVREMENT DE PROTECTION D = 150 X 126
9	0101184	ROHRHEIZKÖRPER 36KW 415V 1GEL7C733001	HEATING ELEMENT F. BOILER 36 KW; 415 VOLTS	RESISTANCE A. BRIDE 36 KW 415 V
10	0408229	DICHTUNG F. WASSERWAERMER 40KW EPDM 144X102X3 MM	GASKET F. HOT WATER APP. 40KW EPDM 144X102X3 MM	GARNITURE D'ETANCHEITE 40KW EPDM 144X102X3 MM
11	0233045	NORMA-KLEMME 1248030026 20-32 MM	NORMA HOSE CLAMP 12480300 20-32 MM 9 MM	BORNE DE TUYAU NORMA 20-32 MM 9 MM
12	0165110	VINYLANSCHLAUCH NW25 ART. NR. 1000152	HOSE VINYLAN NW25 NO. 1000152	TUYAU VINYLAN NW25 NO. 1000152

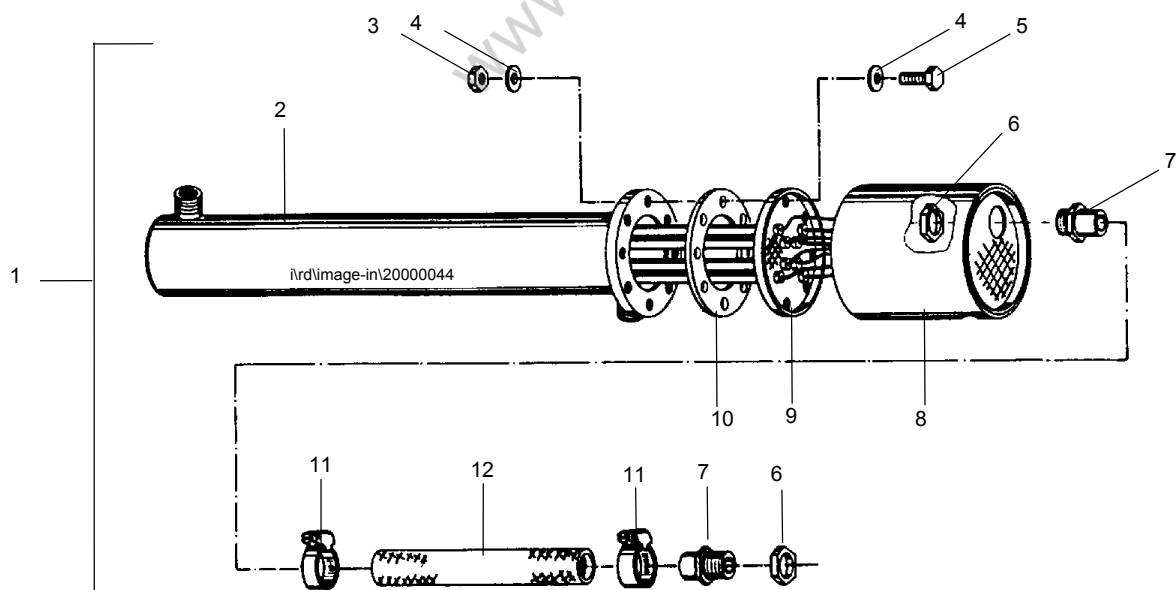

POS. 6.9 BOILER FÜR DEMI-WASSER



POS. 6.9 BOILER FOR DEMI-WATER

POS. 6.9 SURCHAUFFEUR POUR EAU-DEMI

POS.	IDENT.-NR. IDENT.-NO.	BEZEICHNUNG	DESIGNATION	DESIGNATION
1	8400031	BOILERGEHÄUSE ABGEDRŠCKT EB12/15 KW, 1 FLANSCH	BOILER COATING WELDED EB 12/18-61.00.3 SIZE 1	MANTEAU DU SURCHAUFFEUR EB 12/18-61.00.3 NO.1
2	0408036	DICHTRING AFM 34 200X150X2 MM 10 LOCH	FLATPACKING EB 36 SIZE 1/2	JOINT PLAT EB 36 NO.1/2
3	8400278	DECKEL F. EB KOMPL. MIT MUFFE 4301	COVER FOR BOILER CPL. 4301	COUVERCLE P. SURCHAUFFEUR CPL. 4301
4	8400022	DECKEL KPL MIT 3 MUFFEN D=200 BAUGR. 4301	COVER WITH 2 SOCKETS AND REGULATING SOCKET EB 21	COUVERCLE AVEC 2 MANCHONS ET MANCHON REGULATEUR EB
5	0409008	KUPFERDICHTUNG 1 1/2"	COPPER PACKING 1 1/2"	JOINT CUIVRE 1 1/2"
6	0101148	ERSATZ 9502872 HEIZKÖRPER 20.21342.000	HEATING ELEMENT 20.21342 9 KW 220 V 460 MM	RESISTANCE 9 KW 220 V
7	0101146	HEIZKÖRPER 20.21341.000	HEATING ELEMENT 20.21341 7,5 KW 220 V 415 MM	RES.DU SURCHAUFFEUR 7,5KW SANS CAPUCH.LONGEUR 415MM
8	0101144	HEIZKÖRPER 20.21341.000	HEATING ELEMENT 20.21341 6 KW 220 V 415 MM	RES.D.SURCHAUFFEUR 6 KW SANS CAPUCH.LONGEUR 415MM
9	0101142	HEIZKÖRPER 20.21340.000	HEATING ELEMENT 20.21340 4,5 KW 220 V 380MM	RES.DU SURCHAUFFEUR 4,5KW SANS CAPUCH.LONGEUR 380MM
10	0620315	ABDECKKAPPE KPL. K260/1/2 FŠR HEIZKOERPER	CAPS COMPLETE FOR HEATING ELEMENTS	CAPUCHONS COMPLETS POUR RESISTANCE
11	0162052	VERSCHRAUBUNG SKINTOP ST 13,5	SCREWING SKINTOP ST 13,5	VISSAGE SKINTOP ST 13,5
12	0335008	SKT.-MUTTER M 5	HEXAGON NUT M 5,DIN 934 4301	ECROU A 6 PANS M 5 DIN 934,4301
13	8400092	REGLERMUFFE 1.4301 SW 19-18	REGULATING SOCKET 1.4301 SW 19-18	MACHON DE REGULATEUR 1.4301 SW 19-18
14	0108004	TEMPERATURREGLER LANG 1/2" MIT GEHÄUSE	THERMO CONTROL BUERKERT LONG 1/2" WITH SHELL	REGULATEUR DE TEMPERATURE JUSQU'A 18 KW AVEC CORPS
15	8400136	FLANSCH FÜR BOILER 30-36 KW	FLANGE RING, VARNISHED	RING ANNEAU DE BRIDE, LAQUEE
16	0304014	INBUSSCHRAUBE M 8X25	CYLIND.HEAD SCREW W.HEXA. SOCKET M8X25 DIN 912	VIS A TETE CYLINDR.A SIX PANS CREUX M8X25 DIN 912
17	8400138	BOILERGEHÄUSE GESCHWEIŠT 36 KW D=150X520	HOUSING OF BOOSTER HEATER	BOITE DE SURCHAUFFEUR
18	8400017	DECKEL 1 HEIZKOERPER- MUFFE 4301	COVER WITH 1 SOCKET EB 21 /36-65.00.4	COUVERCLE AVEC 1 MANCHON EB 21/36-65.00.4
19	8400016	BOILERDECKEL KOMPLETT 30-36 KW	BOILER COVER W/2 SOCKETS	COUVERCLE SANS REGULATEUR

POS. 6.9 BOILER FÜR DEMI-WASSER



POS. 6.9 BOILER FOR DEMI-WATER

POS. 6.9 SURCHAUFFEUR POUR EAU-DEMI

POS.	IDENT.-NR. IDENT.-NO.	BEZEICHNUNG	DESIGNATION	DESIGNATION
------	--------------------------	-------------	-------------	-------------

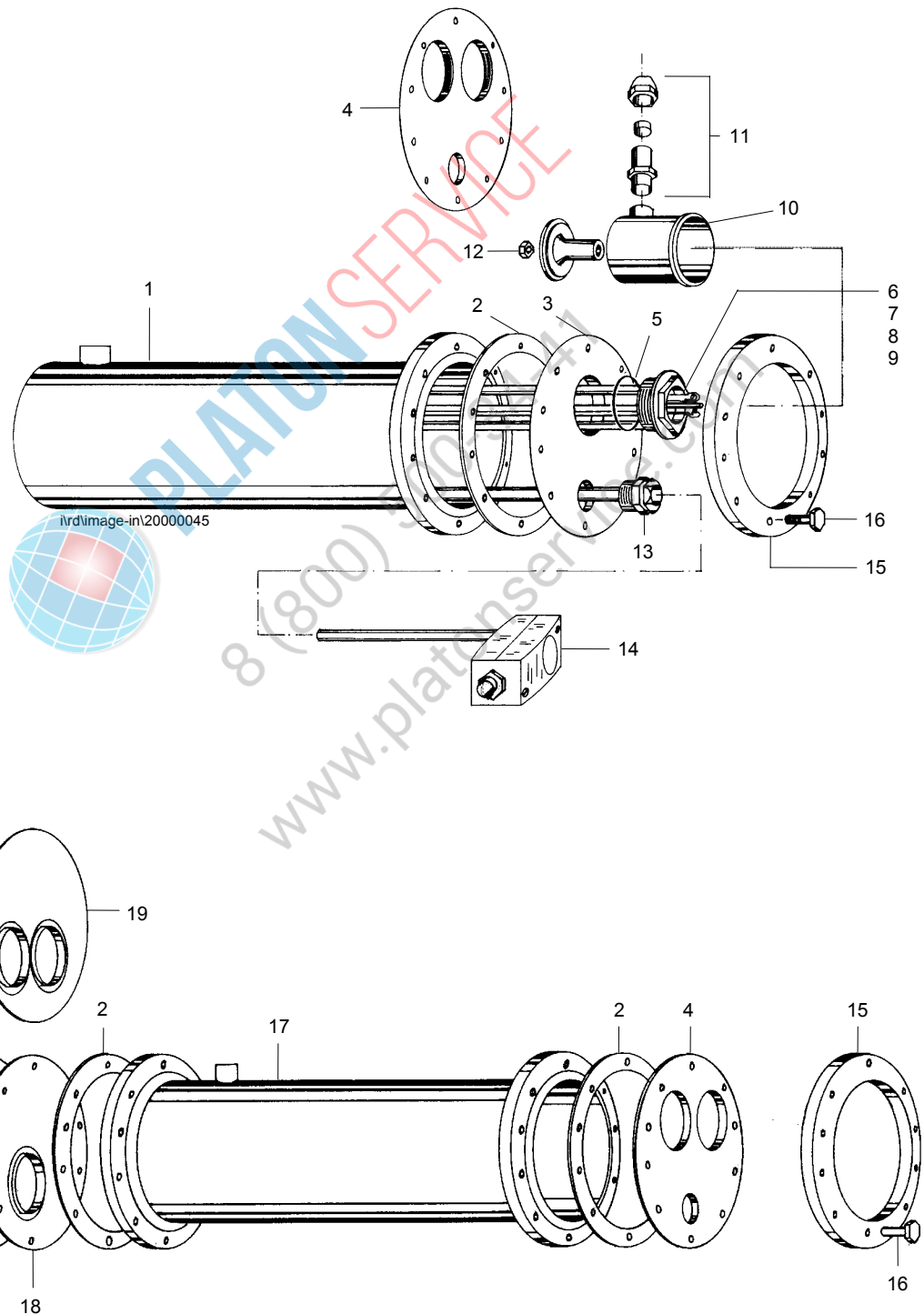

POS. 7.1/7.2 WÄRMETAUSCHER



POS. 11.4.2 HEAT EXCHANGER

POS. 11.4.2 ECHANGEUR DE CHALEUR

POS.	IDENT.-NR. IDENT.-NO.	BEZEICHNUNG	DESIGNATION	DESIGNATION
------	--------------------------	-------------	-------------	-------------

		<u>GÜLTIG BIS 02/96</u>	<u>VALID TO 02/96</u>	<u>VALABLE JUSQU'AU 02/96</u>
	POS. 7.1	WÄRMETAUSCHER	HEAT EXCHANGER	ECHANGEUR DE CHALEUR
1	0254018	KUEHLER 60 QM CU 6.00.005.0	COOLER 60 M2 CU 6.00.005.0	REFROIDISSEUR 60 M2 CU 6.00.005.0
	0254019	KUEHLER 60 QM 6.00.005.0 V2A 1.4301	COOLER ST/ST 1.4301 60 M2 6.00.005.0	REFROIDISSEUR 60 M2 1.4301 6.00.005.0

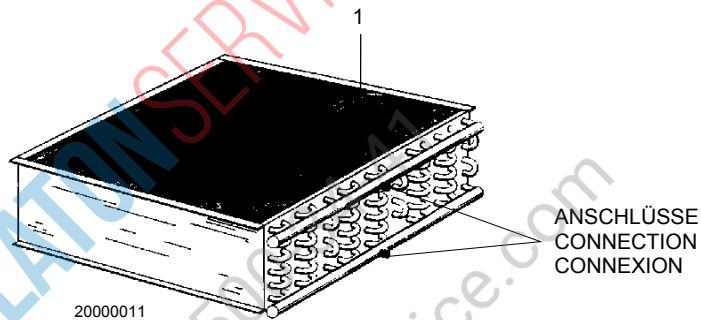

		<u>GÜLTIG AB 02/96</u>	<u>VALID FROM 02/96</u>	<u>VALABLE A PARTIR DE 02/96</u>
	POS. 7.2	WÄRMETAUSCHER	HEAT EXCHANGER	ECHANGEUR DE CHALEUR
1	0254025	KUEHLER 180329-3A	COOLER 180329-3A	REFROIDISSEUR 180329-3A
	0254026	KUEHLER 1.4435 2520.180.814	COOLER 2520.180.814	REFROIDISSEUR 2520.180.814

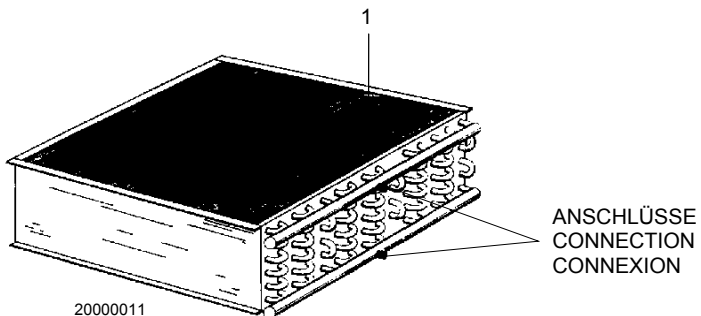

POS. 7.3 ABSAUGGEBLÄSE



POS. 7.3 EXTRACTION FAN

POS. 7.3 VENTILATEUR D'ASPIRATION

POS.	IDENT.-NR. IDENT.-NO.	BEZEICHNUNG	DESIGNATION	DESIGNATION
1	0550052	GEBLÄSE AXIAL FA035-VDL.2C.5	FAN AXIAL FA035-VDL.20.5	VENTILATEUR AXIAL FA035-VDL.20.5
	0550057	AXIALVENTILATOR FC031-4DF.2A.6	FAN AXIAL FC031-4DF.2A.6	VENTILATEUR AXIAL FC031-4DF.2A.6

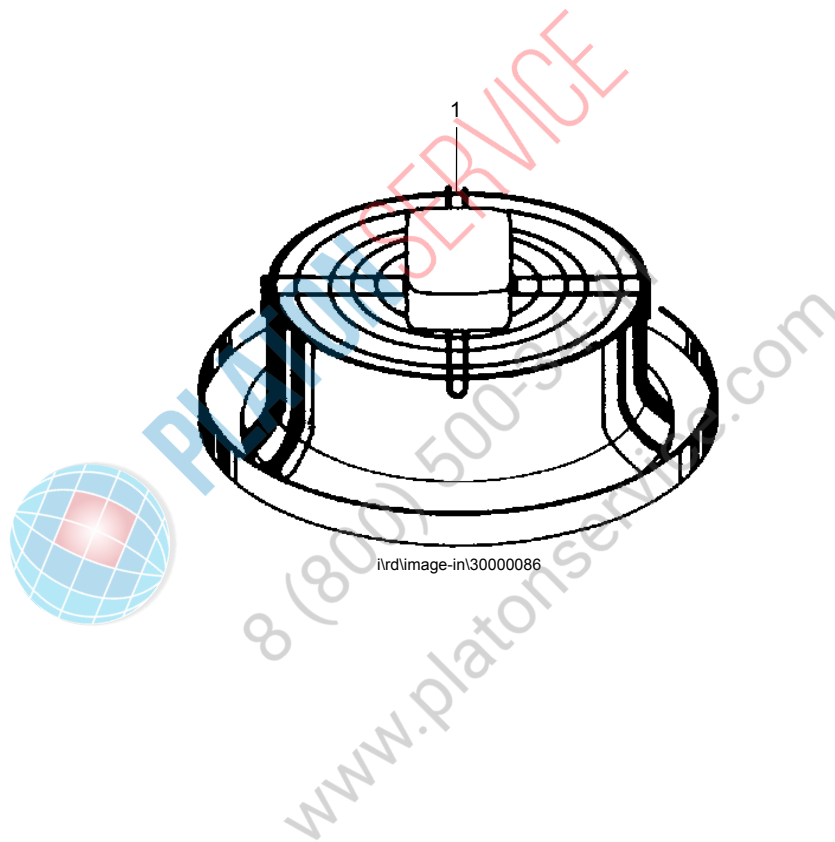

ird\image-in\30000086

POS. 7.4 RADIALGEBLÄSE (MRL-0,75 KW)



POS. 7.4 RADIAL FAN

POS. 7.4 VENTILATEUR RADIAL

POS.	IDENT.-NR. IDENT.-NO.	BEZEICHNUNG	DESIGNATION	DESIGNATION
1	0550034	MOTOR RF 0,75/4-7 0,75KW 380-415/220-240V 50/60HZ	THREE-PHASE FLANGE MOTOR 0,75 KW, TYPE FDR 80/B 4Q	MOTEUR TRIPHASE 0,75 KW TYPE FDR80/B 4 Q 1410 TR
2	8180027	SCHLEUDERSCHEIBE CUZN D90X19-11,5	CENTRIFUGAL DISC D=90X 15,5 B 230K- 17.02.11.5	RONDELLE CENTRIFUGE D=90 X15,5 B 230K-17.02.11.5
3	8180026	DISTANZ LÜFTERMOTOR 4301 D=17X10	DISTANCE PIECE F. EXTRAC- TION MOTOR D=17,2X2X10	PIECE DE DISTANCE POUR VENTILATEUR D=17,2X2X10
4	8130091	MOTORPLATTE FÜR MRL 4301 280X280X2	MOTOR SUPPORT F. MRL-FAN 280X280X2 4301	PLAQUE SUPPORT DE MOTEUR
5	8180036	LÜFTERRAD MIT NABE	VENTILATOR WHEEL WITH HUB D=250	ROUE DE VENTILATEUR D=250 AVEC MOYEU
6	8180023	U-SCHEIBE MRL 250/120 D=34XD=6,5X2 4301	DISC D=34XD=6,5X2 4301	RONDELLE D=34XD=6,5X2 4301
7	0302001	SKT.-SCHRAUBE M 6X15	HEXAGON SCREW M6 X 15,	VIS A 6 PANS M 6 X 15,
8	0340006	U-SCHEIBE MS. VERN. 8,4 X 18 X 2 MM	WASHER BRASS NICKED 8,4 X 18 X 2 MM	RONDELLE 8,4 X 18 X 2 EN LAITON NICKELE
9	0335015	SKT.-MUTTER M 8	HEXAGON NUT M 8	ECROU A 6 PANS M 8
10	0341005	FEDERRING A 10 MM	FEATHER KEY A 10 MM	RONDELLE RESSORT A 10 MM
11	0302022	SKT.-SCHRAUBE M10X30	HEXAGON SCREW M10X30	VIS A 6 PANS M10 X 30

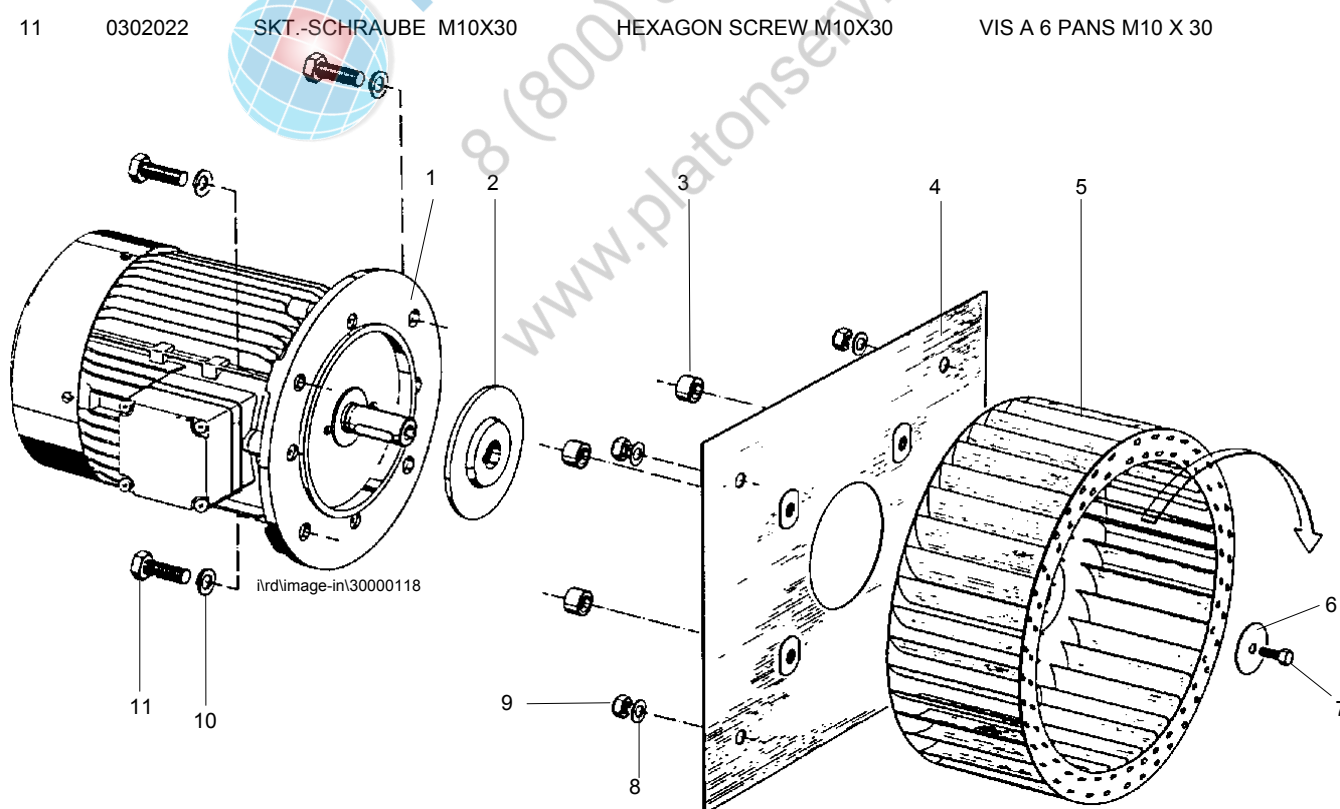

POS. 8.1 FRISCHWASSERSPARSCHALTER



POS. 8.1 FRESH WATER SAVING DEVICE

POS. 8.1 INTERRUPTEUR ECONOMISEUR EAU DE RINCAGE

POS.	TEILE-NR. IDENT.-NO.	BENENNUNG	DESIGNATION	DESIGNATION
	POS. 8.1	<u>FRISCHWASSERSPARSCHALTER FÜR MASCHINEN OHNE PUMPEN KLARSPÜLUNG</u>	<u>FRESH WATER SAVING DEVICE FOR MACHINES WITHOUT PUMP FINAL RINSE</u>	<u>INT. ECONOMISEUR-EAU DE RINCAGE P. MACHINES SANS RINCAGE A POMPE</u>
1	8132529	SCHLEIFER EINFACH-KSP- SCHALTER 485*50	SLIDER SIMPLE FRESH WATER RINSING SWITCH 485*50	INTERRUPTEUR ECONOMISEUR SIMPLE RINCAGE FINAL 485*50
2	8132481	SCHWENKARM LANG,SCHWEIß- TEIL 220*78*75	SWIWELLING ARM LONG WELDING PART 220*78*75	BRAS PIVOTANT LONG PIECE A SOUDER 220*78*75
3	8132483	SCHWENKARM KURZ D=8 X 145 1.4301	SWIWELLING ARM SHORT D=8 X 145 1.4301	BRAS PIVOTANT COURT D=8 X 145 1.4301
4	0140206	RINGMAGNET HARTFERRIT 24/16 D=31X5,3X15 MM	RING MAGNET HARD FERRITE 24/16 D=31X5,3X15 MM	AIMANT ROND EN FERRITE DURE 24/16 D=31X5,3X15 MM
5	0430002	ZUGFEDER V2A 15 X 42 X 1 MM	TENSION SPRING 15 X 42 X1 4301	RESSORT DE TENSIONS 15 X 42 X , 4301

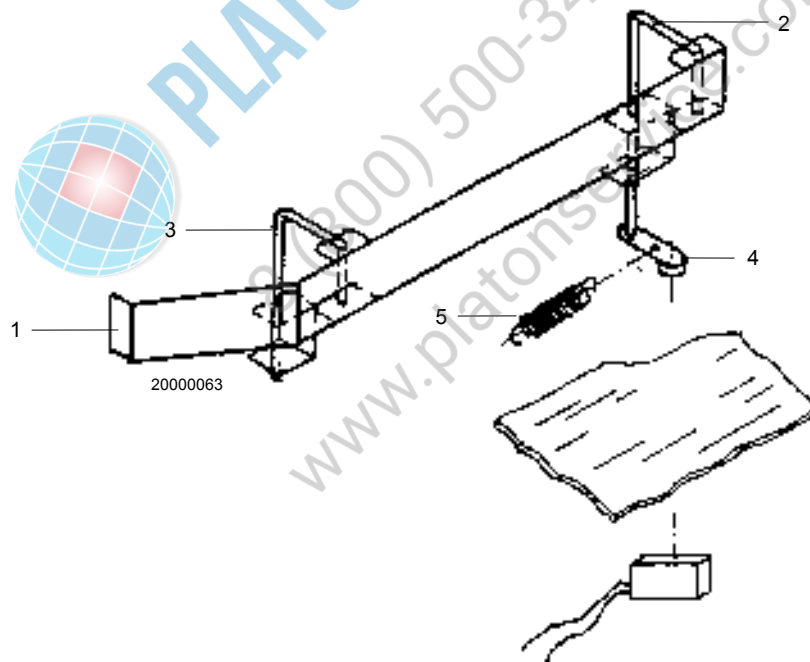

	POS. 8.2	<u>FRISCHWASSERSPARSCHALTER FÜR MASCHINEN OHNE PUMPEN KLARSPÜLUNG</u>	<u>FRESH WATER SAVING DEVICE FOR MACHINES WITHOUT PUMP FINAL RINSE</u>	<u>INT. ECONOMISEUR-EAU DE RINCAGE POUR MACHINES SANS RINCAGE A POMPE</u>
1	8132477	SCHLEIFER DOPPEL-NSP- SCHALTER 600*50	SLIDER POWER FINAL RINSE SWITCH 600*50	INTERRUPTEUR ECONOMISEUR DOUBLE RINCAGE FINAL 600*50

POS. 9.0 EINLAUFTAKTSCHALTER



POS. 9.0 FEEDING INTERVAL SWITCH

POS. 9.0 INTERRUPTEUR DE SYNCRONISATION

POS	TEILE-NR. IDENT.-NO.	BENENNUNG	DESIGNATION	DESIGNATION
1	8130668	SCHALTERFAHNE KPL.	CONTROL LEVER CPL.	LEVIER DE COMMANDE CPL.
2	0430002	ZUGFEDER V2A 15X42X1 MM	TENSION SPRING V2A 15X42X1 MM	RESSORT DE TENSIONS V2A 15X42X1 MM
3	0140206	RINGMAGNET HARTFERRIT 24/16 D=31X5,3X15 MM	RING MAGNET HARD FERRIT 24/16 D=31X5,3X15 MM	AIMANT ROND EN FERRITE DURE 24/16 D=31X5,3X15 MM
4	8130411	LAGERWINKEL 1.4301 60X22X2-40	BEARING ANGLE 1.4301 60X22X2-40	ANGLE DE LOGEMENT 1.4301 60X22X2-40
5	0122056	GRENZTASTER 641.4212.404 MAK-1212-F-5-VDR	LIMIT SWITCH / 5 M CABLE MAK-1212-F-3	INTERRUPTEUR-LIMITEUR MAK-1212-F-3

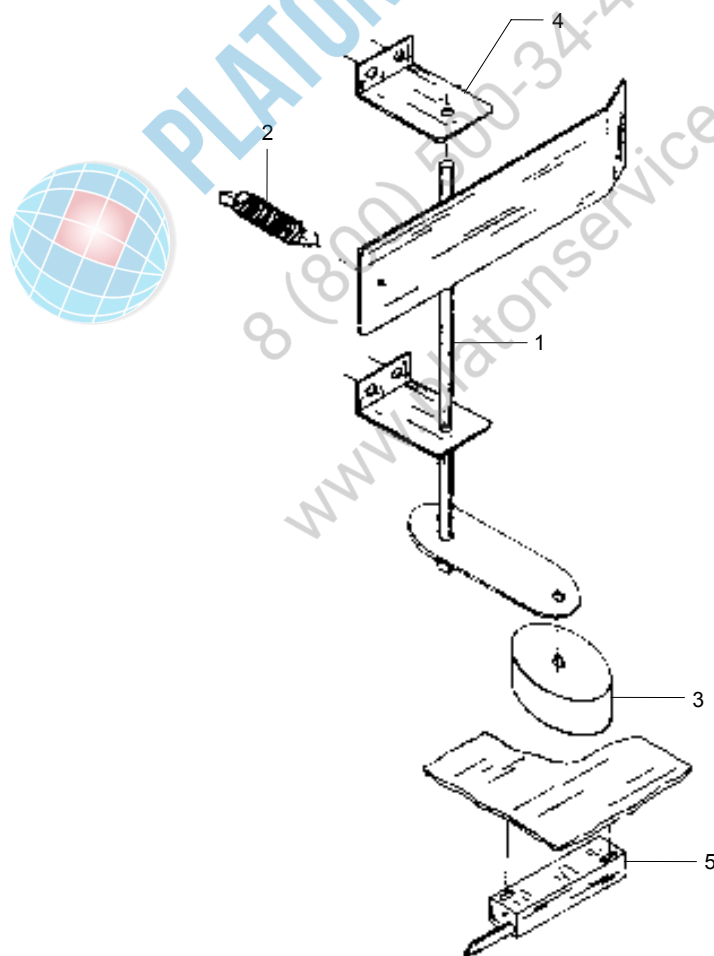

POS. 10.0 SPRITZSCHUTZVORHANG



POS. 10.0 CURTAIN

POS. 10.0 RIDEAU

POS.	TEILE-NR. IDENT.-NO.	BENENNUNG	DESIGNATION	DESIGNATION
1	8104014	AUFHÄNGUNG 95X20X2 4301	FIXATION 95X30X2 4301	FIXATION 95X30X2 4301
2	8132550	VORHANG 650*445 EINLAUF / AUSLAUF / TROCKNUNG	CURTAIN 650*445 FEEDING / DISCHARGE / DRYING	RIDEAUX 650*445 ENTREE / SORTIE / SECHAGE
3	8132553	VORHANG WASCHZONE 650*325	CURTAIN WASH ZONE 650*325	RIDEAUX ZONE DE LAVAGE 650*325
4	8132556	VORHANG 610*445 AUSLAUF / TROCKNUNG NUR BEI ISOLIERTER MASCHINE	CURTAIN 610*445 DISCHARGE / DRYING ONLY FOR INSULATED MACHINE	RIDEAUX 610*445 SORTIE / SECHAGE UNIQUEMENT P. MACHINE ISOLEE

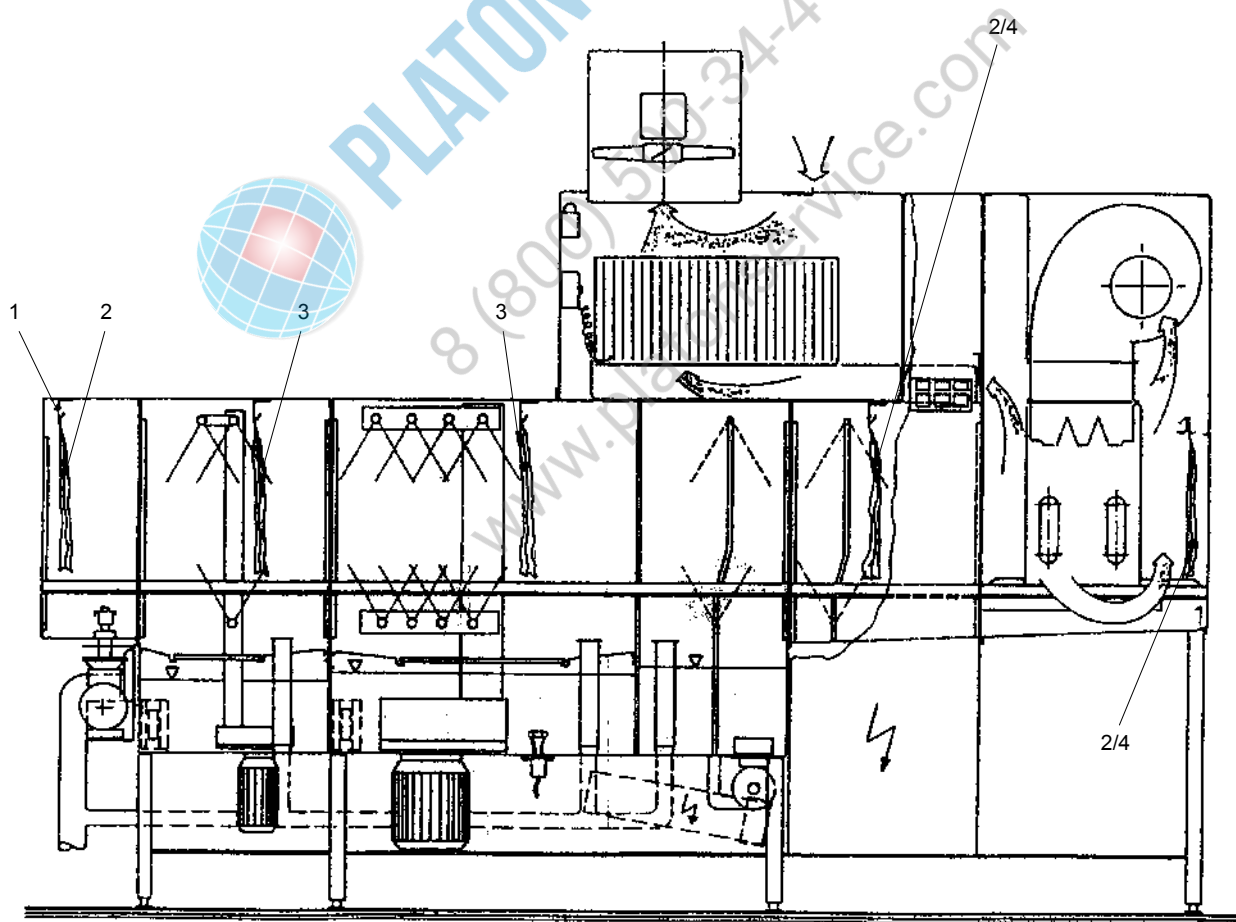

POS. 11.0 ABLAUF



POS. 11.0 DRAIN

POS. 11.0 VIDANGE

POS.	IDENT.-NR. IDENT.-NO.	BEZEICHNUNG	DESIGNATION	DESIGNATION
1	8101478	STANDROHR KOMPL. F. TÜR- SCHLIEßUNG D=50X301,25	DRAIN PLUG D=50X301,25	BONDE DE TROP PLEIN D=50X301,25
2	0237008	STANDR.VENT.-MUTTER 9942 2" X 88 MM MS.	NUT. NO. 9942 MS 2" X 88 MM	ECROU NO. 9942 MS 2" X 88 MM
3	0408224	GUMMIDICHTUNG EPDM 78X60X2 MM	RUBBER PACKING 78X60X2MM 78X60X2MM	JOINT EN CAOUTCHOUC 78X60X2MM
4	0237100	ABLAUF G 2" KOMPLETT 434131240	DRAIN 2" CPL. 434131240	VIDANGE 2" CPL. 434131240
5	0620358	SIEB FUER STANDROHR K 363	SIEVE F. DRAIN PLUG K 363	TAMIS POUR TUYAU DE VIDANGE K 363

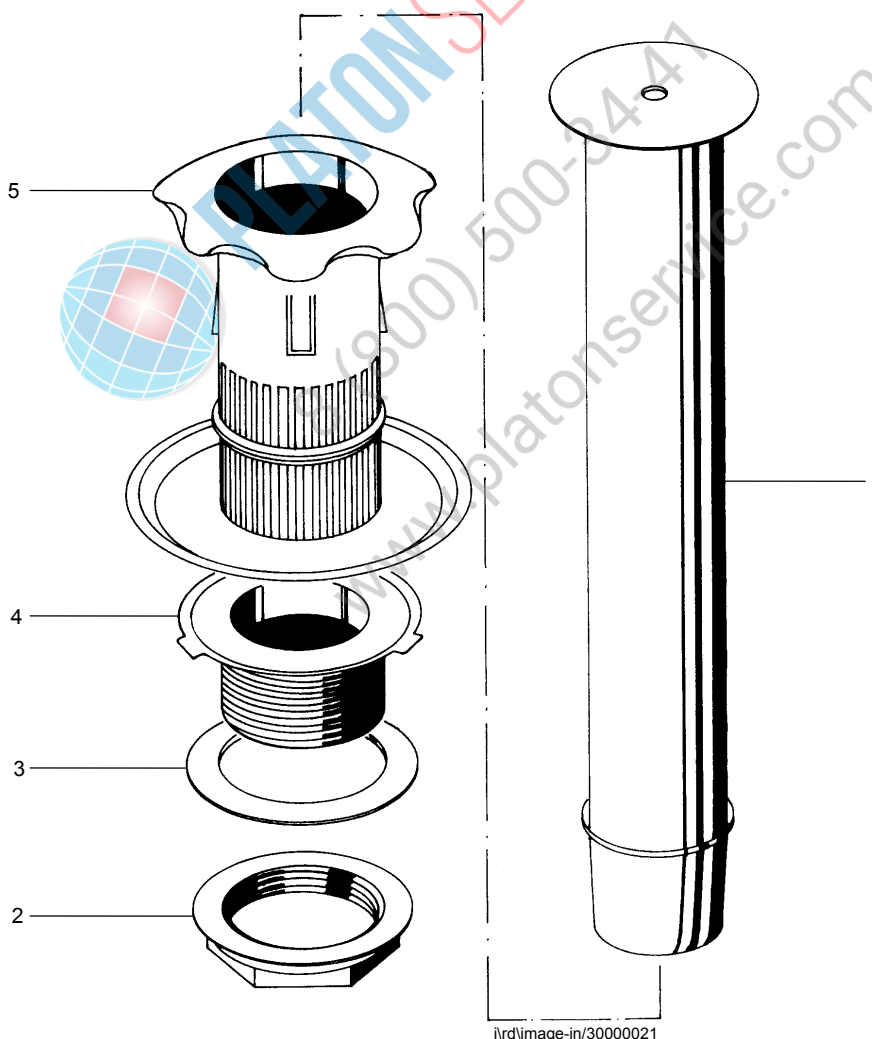

POS. 12.1 FÜRFÜHRUNG



POS. 12.1 DOOR GUIDANCE

POS. 12.1 GUIDAGE DE PORTE

POS.	IDENT.-NR. IDENT.-NO.	BEZEICHUNG	DESIGNATION	DESIGNATION
1	8132301	TÜRGRIFFPROFIL TÜR 500 MM	DOOR HANDLE PROFILE DOOR 500 MM	PROFILE DE POIGNEE DE PORTE PORTE 500 MM
2	8132302	TÜRGRIFFPROFIL TÜR 800 MM	DOOR HANDLE PROFILE DOOR 800 MM	PROFILE DE POIGNEE DE PORTE PORTE 800 MM
3	8132303	TÜRGRIFFPROFIL TÜR 1200 MM	DOOR HANDLE PROFILE DOOR 1200 MM	PROFILE DE POIGNEE DE PORTE PORTE 1200 MM
4	8132246	TÜRFÜHRUNGSPROFIL 640 LG "S" SCHWARZ	DOOR GUIDE RAIL 640 LG „S“ BLACK	RAIL DE GUIDAGE DE PORTE 640 LG „S“ NOIR
5	0325056	FLACHRUNDSCHRAUBE DIN 603 M5X30 MM 1.4301	SAUCER HEAD SCREW DIN 603 M5 X 25 MM 1.4301	BOULON A TETE BOMBEE DIN 603 M5 X 25 MM 1.4301

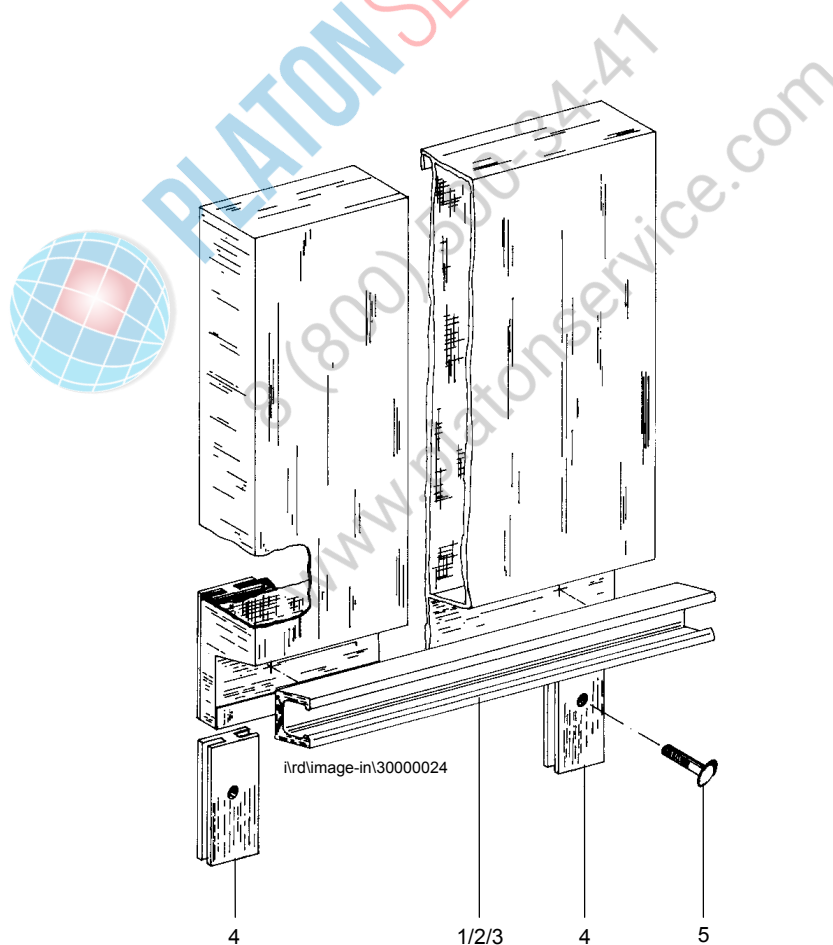

POS. 12.2 TÜR HÖHE 2



POS. 12.2 DOOR HEIGHT 2

POS. 12.2 PORTE HAUTEUR 2

POS.	IDENT.-NR. IDENT.-NO.	BEZEICHNUNG	DESIGNATION	DESIGNATION
1	8100910	LAGERBOLZEN KURZ D=8*78	BOLT SHORT D=8*78	BOULON D=8*78
2	8100909	LAGERBOLZEN LANG D=8*149	BOLT LONG D=8*149	BOULON D=8*149
3	0351004	SPLINT 2 X 20 MM	SPLIT PIN D= 2 X 20	GOUPILLE D= 2 X 20
4	8100868	ROLLFEDERHALTERUNG 1.4301 60*60,5*95	SCROLL SPRING SUPPORT 1.4301 60*60,5*95	SUPPORT POUR RESSORT A CROSSE 1.4301 60*60,5*95
5	0620284	LAGERROLLE 1/2" K280	SUPPORT ROLL 1/2 K 280	ROULEAU SUPPORT 1/2 K 280
6	8130763	TÜRANSCHLAG 500/800 MM TÜR	DOOR CATCH 500/800 MM DOOR	ARRET DE PORTE 500/800 MM PORTE
7	8130764	TÜRANSCHLAG 1200 MM TÜR	DOOR CATCH 1200 MM DOOR	ARRET DE PORTE 1200 MM PORTE
8	8132527	TÜRANSCHLAG MIT ABLAUFSCHLIEßUNG 500/800 MM TÜR	DOOR CATCH WITH DRAIN CLOSING SYSTEM 500/800 MM TÜR	ARRET DE PORTE DE FERMETURE DE VIDANGE 500/800 MM TÜR
9	8132528	TÜRANSCHLAG MIT ABLAUFSCHLIEßUNG 1200 MM TÜR	DOOR CATCH WITH DRAIN CLOSING SYSTEM 1200 MM DOOR	ARRET DE PORTE DE FERMETURE DE VIDANGE 1200 MM PORTE

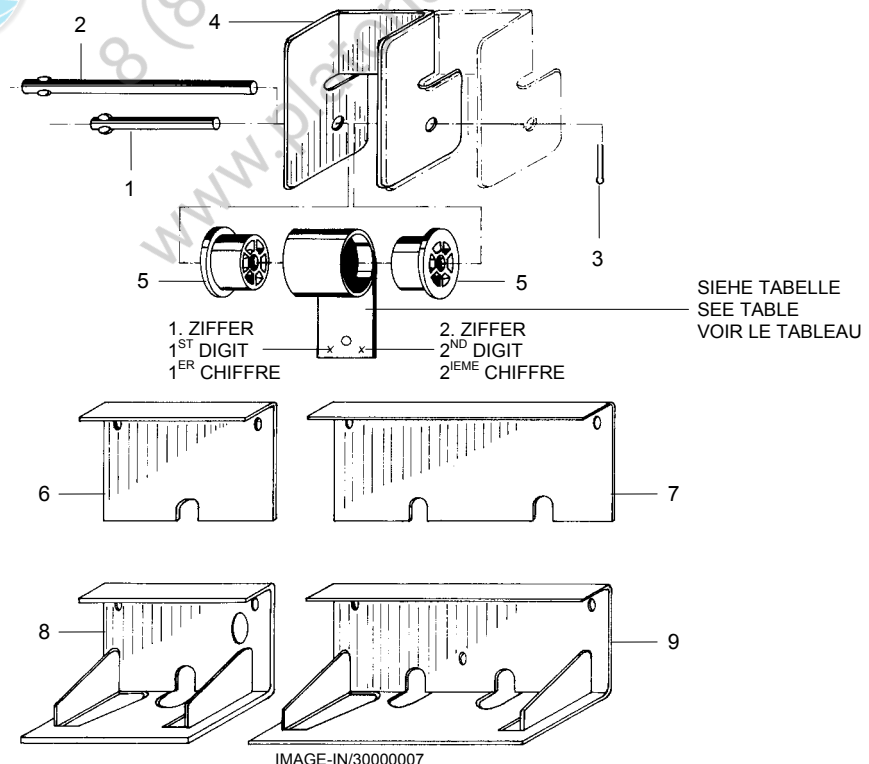

POS. 12.2 TÜRGEWICHTSAUSGLEICH



POS. 12.2 DOOR COUNTER WEIGHT

POS. 12.2 EQUILIBRAGE DE POIDS DE PORTE

POS.	IDENT.-NR. IDENT.-NO.	BEZEICHNUNG	DESIGNATION	DESIGNATION
------	--------------------------	-------------	-------------	-------------

BEIM EINBAU DER ROLLFEDERN IST DIE IN DER TABELLE ANGEGEBENE FEDERNKOMBINATION EINZUHALTEN.
AUF JEDER ROLLFEDER SIND AM AUßENENDE ZWEI ZIFFERN EINGEPRÄGT; DIESE KENNZEICHNEN DEN FEDERTYP.

DIE 1. ZIFFER STEHT FÜR DIE ZUGKRAFT
DIE 2. ZIFFER STEHT FÜR DIE FERLÄNGE

Z. B. 7 ENTSPRICHT 70 N (ODER 7 KG)
Z. B. 1 = K-TRONIC

WHEN INCORPORATING THE ROLL SPRINGS THE SPRING COMBINATION INDICATED IN THE LIST BELOW HAS TO BE OBSERVED.
AT EACH ROLL SPRING 2 FIGURES ARE STAMPED AT THE END INDICATING THE SPRINGTYPE:

THE 1ST FIGURE INDICATES THE TENSION FORCE
THE 2ND FIGURE INDICATES THE SPRING LENGTH

F. EX. 7 CORRESPONDS TO 70 N (OR 7 KG)
F. EX. 1 = K-TRONIC

LORS DE L'INSTALLATION DES RESSORTS, OBSERVER LA COMBINAISON DE RESSORTS DANS LE TABLEAU CI-APRES.
A L'EXTREMITE DE CHAQUE RESSORT SONT IMPRIMES DEUX CHIFFRES. CEUX-CI DESIGNENT LE TYPE DE RESSORT:

LE 1^{ER} CHIFFRE DESIGNER LA FORCE DE TRACTION
LE 2^{EME} CHIFFRE DESIGNER LA LONGUEUR DU RESSORT

P. EX. 7 CORRESPOND A 70 N (OU 7 KG)
P. EX. 1 = K-TRONIC

MASCHINENTYP MODEL TYPE DE MACHINE	TÜRHOHE (MM) DOOR HEIGHT HAUTEUR DE PORTE	TÜRBREITE (MM) DOOR WIDTH LARGEUR DE PORTE	FEDERKOMBINATION FÜR EINE TÜR: SPRING COMBINATION FOR ONE DOOR: COMBINAISON DE RESSORTS POUR UNE PORTE		ARTIKELNUMMER PART NO. N ^O . D'ARTICLE
			FEDERTYP SPRING TYPE TYPE DE RESSORT	STÜCKZAHL JE TÜR NO. PER DOOR N ^O . DE PIECES PAR PORTE	
K-TRONIC K201	664	500	5 1	2	0 431 070
		800	7 1	2	0 431 071
		1200	5 1	4	0 431 070

POS. 13.1 MOTOREINHEIT



POS. 13.1 MOTOR UNIT

POS. 13.1 MOTEUR DE TRANSPORT

POS.	TEILE-NR. IDENT.-NO.	BENENNUNG	DESIGNATION	DESIGNATION
1	0530105	GETRIEBEMOTOR MVBE 24606 I=246:1 0545999 5,7/3,8	GEAR MOTOR MVBE 24606 F. TRANSPORT 5,7/3,8	MOTEUR D'ENTRAINEMENT MVBE24606 I=246:1 0545999 5,7/3,8
	0530106	GETRIEBEMOTOR MVBE 14406 I=144:1 0545999 9,8/6,2	DRIVE MOTOR MVBE 14406 I=144:1 0545999; 9,8/6,2	MOTEUR D'ENTRAINEMENT MVBE 14406; 9,8/6,2
	0530101	GETRIEBEMOTOR SCHNECKENR. CF10-G71 M6/4 380V	GEAR MOTOR CF10-671 M6/4 5,8/9,0 R/MIN. 70NM 380V	MOTO-REDUCTEUR CF10-671 M6/4 5,8/9,0 R/M 380V50HZ
	0530102	GETRIEBEMOTOR 380-415V 50HZ CF10-M1 C6/4	GEAR MOTOR CF10-671 M6/4 12/18R/M. 70NM 380V, 50HZ	MOTO-REDUCTEUR CF10-671 M6/4 12/18 R/M,70NM,380V
2	8130076	STECKKUPPLUNG Ø35X20-90 CUZN	FIXING CLUTCH Ø35X20-90 CUZN	CONTACT A FICHES 35X20-90
3	0355108	PASSFEDER DIN 6885 A 6 X 6 X 30 MM 1.4301	FEATHER KEY DIN 6885 A 6 X 6 X 30 MM 1.4301	RESSORT D'AJUSTAGE 6X6X30 6 X 6 X 30 MM 1.4301
4	8130377	WELLE F. KURBELTRIEB 4301 D=20X137	SHAFT FOR CRANK MECHANISM 4301 D=20X137	ARBRE POUR COMMANDE A MANIVELLE 4301 D=20X137
5	8130379	GLEITLAGER WERKSTOFF"S" D=47X19	SLIDING BEARING MATERIAL "S" D=47X19	PALIER A GLISSEMENT MATERIEL "S" D=47X19
6	0302003	SECHSKANTSCHRAUBE DIN 933 M 6 X 30 MM, W.-NR.1.4301	HEXAGON SCREW M 6X30 DIN 933,4301	VIS A 6 PANS M 6X30 DIN 933,4301
7	8130078	LAGERGEHÄUSE II D=80X25 MS 58	BEARING HOUSING II MS 58	LOGEMENT DU PALIER II MS 58
8	8130067	LAGERGEHÄUSE I D=80X55 MS	BEARING HOUSING I	LOGEMENT DU PALIER I
9	8130072	KURBELKOPF D=70X36 MS 58	CRANK HEAD	TETE A MANIVELLE
10	8130380	KURBEL MIT KURBELBOLZEN 4301 131X97,5X1,25	CRANK 4301 131X97,5X1,25	MANIVELLE 4301 131X97,5X1,25
11	8130381	KULISSENSTEIN 30X25X50 WERKST -S-	SLIDING BLOCK 30X25X50 MATERIAL "S" K200N-42.01	COULISSEAU 30X25X50 MATERIEL "S" K200N-42.01
12	0302000	SECHSKANTSCHRAUBE DIN 933 M 6 X 10 MM, W.-NR.1.4301	HEXAGON SCREW M 6X10 4301,DIN 933	VIS A 6 PANS M 6X10 4301,DIN 933
13	8130382	AUFLAGE F. ANTRIEBSMOTOR PP D=100X20	SUPPORT FOR DRIVE MOTOR PP D=100X20	SUPPORT POUR MOTEUR D'ENTRAINEMENT PP D=100X20
14	0306056	SENKSCHRAUBE DIN 963 M8 X 40 MM, W.-NR. 1.4301	FLAT HEAD SCREW DIN 963 M8 X 40 MM 1.4301	VIS A TETE CONIQUE M8X40 M8 X 40 MM 1.4301
15	8132098	HEBELARM SCHWEIßTEIL	LEVER ARM WELDING PART	ANGLE DE LEVAGE P. A SUDER
16	0431003	DRUCKFEDER FÜR SCHRAUBEN 105X12,5X2 MM NR. 22690	PRESSURE SPRING 105X12,5X2 MM NR. 22690	RESSORT DE PRESSION 105X12,5X2 MM NR. 22690
17	8132101	SPANNSCHRAUBE M8X217 LANG	TENSION SCREW M8X217 LONG	VIS DE TENSION M8X217 LONGUE
18	0122015	ENDSCHALTER GC-UV 1 AH 6020133	END SWITCH GC - UV 1 AH 6020133	INTERRUPTEUR FIN COURSE GC-UV1H6020133
19	0620230	DISTANZSTUECK K125/6 6 MM	INTERMEDIATE PIECE D=8,5X 6 LONG K 125/6	PIECE INTERMEDIAIRE D=8,5 X 6 LONG K 125/6
20	8132048	BEFESTIGUNG F. ÜBERLAST- SCHALTER 70X50-70	FIXATION FOR OVER LOAD SWITCH 70X50-70	FIXATION POUR DISPOSITIF SURCAHRGE 70X50-70

POS. 13.1 MOTOREINHEIT



POS. 13.1 MOTOR UNIT

POS. 13.1 MOTEUR DE TRANSPORT

POS.	TEILE-NR. IDENT.-NO.	BENENNUNG	DESIGNATION	DESIGNATION
24	0140206	RINGMAGNET HARTFERRIT 24/16 D=31X5,3X15 MM	RING MAGNET HARD FERRITE 24/16 D=31X5,3X15 MM	AIMANT MROND EN FERRITE 24/16 D=31X5,3X15 MM DURE
25	8132097	ABSTÜTZUNG SPANNSCHRAUBE	SUPPORT FOR TENSION SCREW	SUPPORT POUR VIS DE TENSION

12

7



PLATON SERVICE

8 (800) 500-34-41

www.platonservice.com

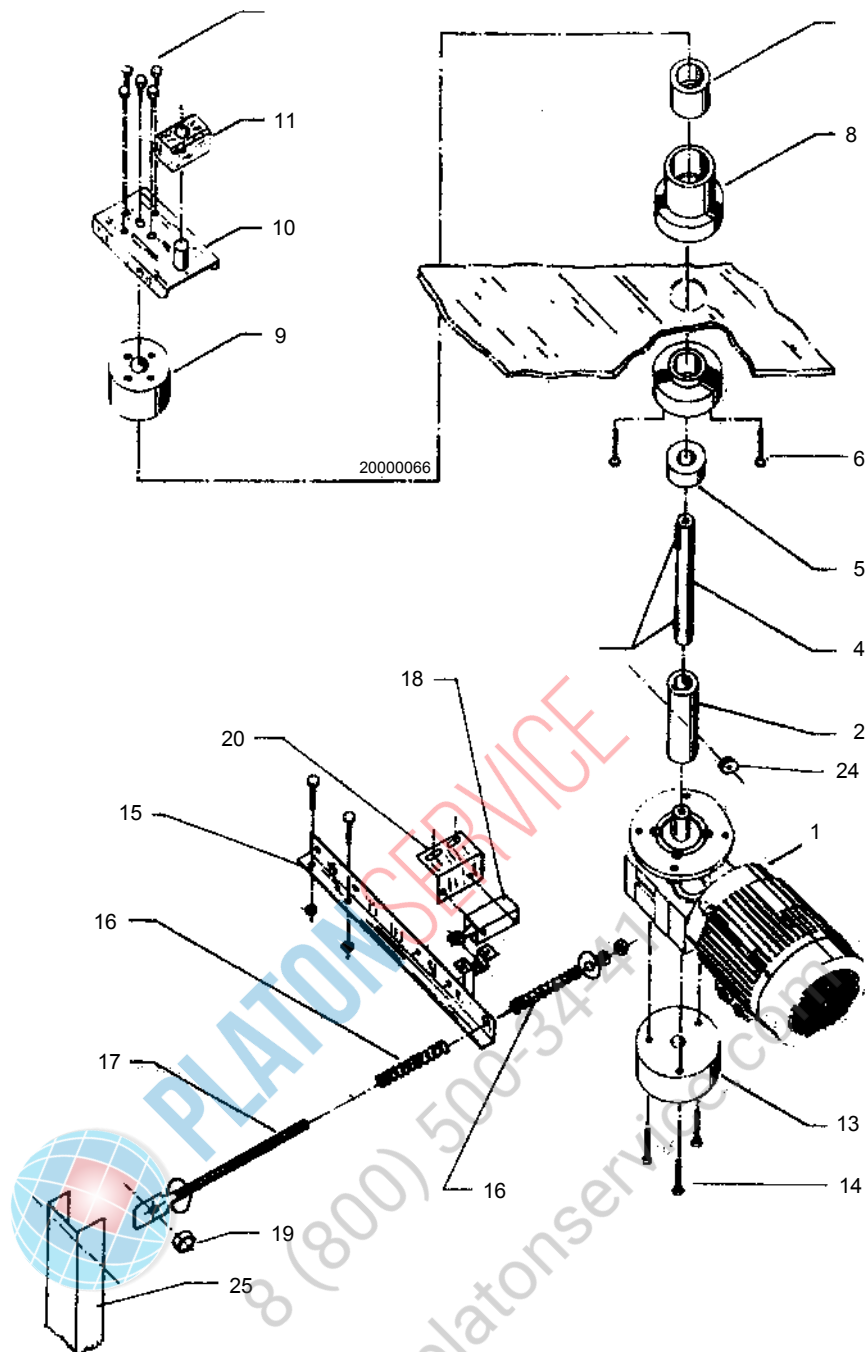

POS. 13.2 KORBTRANSPORTSCHLITTEN



POS. 13.2 BASKET TRANSPORT SLIDE

POS. 13.2 COULISSEAU DE TRANSPORT

POS.	TEILE-NR. IDENT.-NO.	BENENNUNG	DESIGNATION	DESIGNATION
1	8132347	FÜHRUNG TRANSPORTSCHLITTENGUIDANCE BASKET TRANSPORT S-SCHWARZ 30*30-115	SLIDE S-BLACK:. 30*30-115	GUIDAGE COULISSEAU DE TRANSPORT S-NOIR. 30*30-115
2	8132524	QUERPROFIL	CROSS PROFILE	PROFILE TRANSVERSALE
3	8132436	SCHLITTENVERBINDUNG	SLIDE CONNECTION	CONNEXION DE COULISSEAU
4	8130035	TRANSPORTKLINKE	TRANSPORT CATCH	CLIQUET A TRANSPORT
5	0307096	FLACHKOPFSCHRAUBE DIN 85 1.4301 M6X30 MM	FLAT HEAD SCREW DIN 85 1.4301 M6X30 MM	VIS A TETE CONIQUE DIN 85 1.4301 M6X30 MM
6	8132226	KOPPELSTANGENANSCHLUß U22X32,5-65	CONNECTION ROD U22X32,5-65	BRANCHEMENT BARRE DE CONNEXION U22X32,5-65

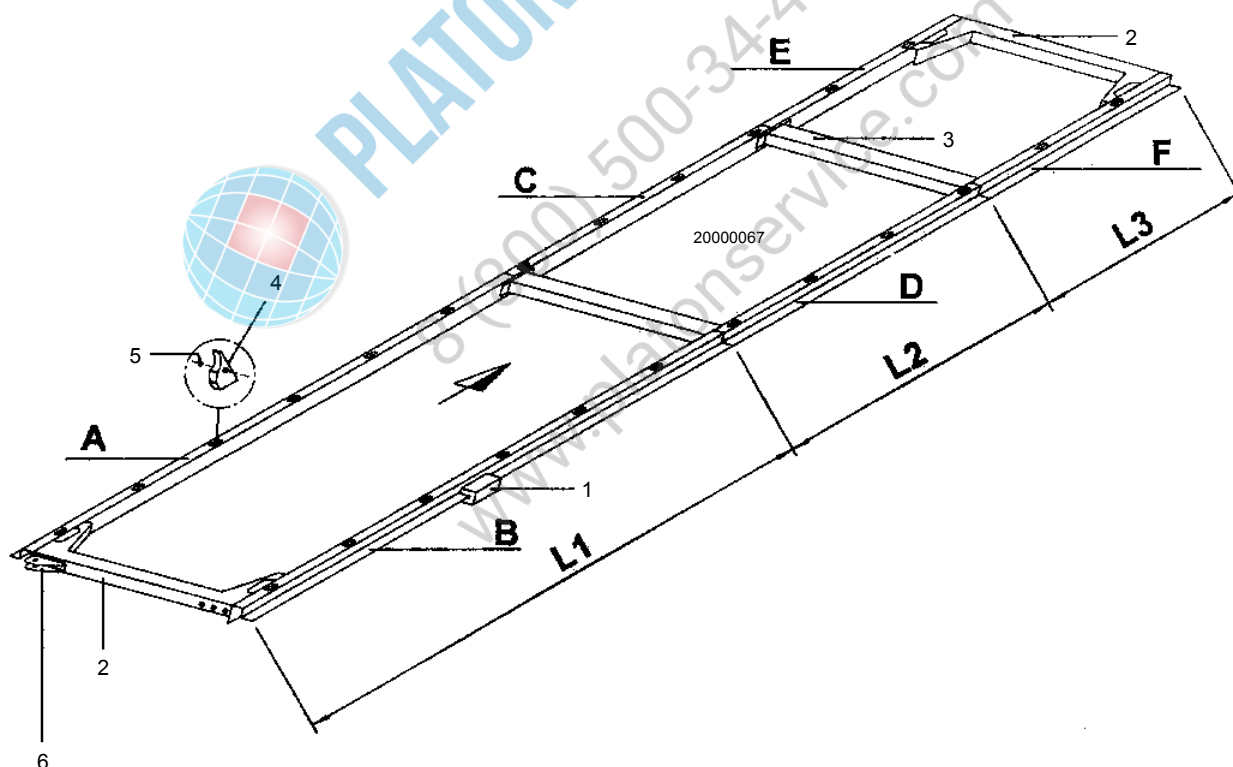

POS. 13.2 KORBTRANSPORTSCHLITTEN



POS. 13.2 BASKET TRANSPORT SLIDE

POS. 13.2 COULISSEAU DE TRANSPORT

POS.	TEILE-NR. IDENT.-NO.	BENENNUNG	DESIGNATION	DESIGNATION
------	-------------------------	-----------	-------------	-------------

TRANSPORTSCHLITTEN BASKET TRANSPORT SLIDE COULISSEAU DE TRANSPORT			
Maschinentyp Type of machine Type de la machine	Länge L1 (mm) Length L1 (mm) Longueur	Links/Left/Gauche=A Rechts/Right/Droite=B	Teile Nr.: Part no. No. de pieces
K 201	1252	A B	8132415 8132416
K 201 P	1652	A B	8132417 8132418
K 201 V	1752	A B	8132419 8132420
K 201 VP	2152	A B	8132421 8132422
K 201 VA	2052	A B	8132423 8132424
K 201 VAP	2452	A B	8132425 8132426

Bei den Maschinentypen K 401 wird der Transportschlitten um 800 mm verlängert

For K401-models add 800 mm extension of basket transport slide.

Pour les machines de la série K 401 le coulisseau de transport est rallonger de 800 mm.

Maschinentyp Type of machine Type de la machine	Länge L2 (mm) Length L2 (mm) Longueur L2 (mm)	Links/Left/Gauche=C Rechts/Right/Droite=D	Teile Nr.: Part no. No. de pieces
K 401	800	C D	8132427 8132428

Tranportschlitten für Trocknungszone TR 1 / TR 2 Basket transport slide for drying section Coulisseau de trasport pour séchage

Maschinentyp Type of machine Type de la machine	Länge L2 (mm) Length L2 (mm) Longueur L2 (mm)	Links/Left/Gauche=E Rechts/Right/Droite=F	Teile Nr.: Part no. No. de pieces
TR 1	600	E F	8132429 8132430
TR 2	900	E F	8132431 8132432

POS. 13.3 TISCHENDSCHALTER



POS. 13.3 TABLE END SWITCH

POS. 13.3 INTERRUPTEUR FIN DE COURSE

POS.	TEILE-NR. IDENT.-NO.	BENENNUNG	DESIGNATION	DESIGNATION
1	8130084	SCHALTHEBEL	SWITCH LEVER	LEVIER DE COMMANDE
2	8130090	GRUNDPLATTE	BASE PLATE	PLAQUE DE MONTAGE
3	8130086	SCHALTERFAHNE, SCHWEIßTEIL 1.4301 D8-160X108	ACTUATING LEVER 1.4301 D8-160X108	LEVIER DE MANOEUVRE 1.4301 D8-160X108
4	0122005	ENDSCHALTER GC-01 HIW	FINAL SWITCH GC-01 HIW	INTERRUPTEUR FINAL GC-01 HIW
5	0430002	ZUGFEDER V2A 15 X 42 X 1 MM	TENSION SPRING 15 X 42 X 1, 4301	RESSORT DE TENSIONS 15 X 42 X 1, 4301

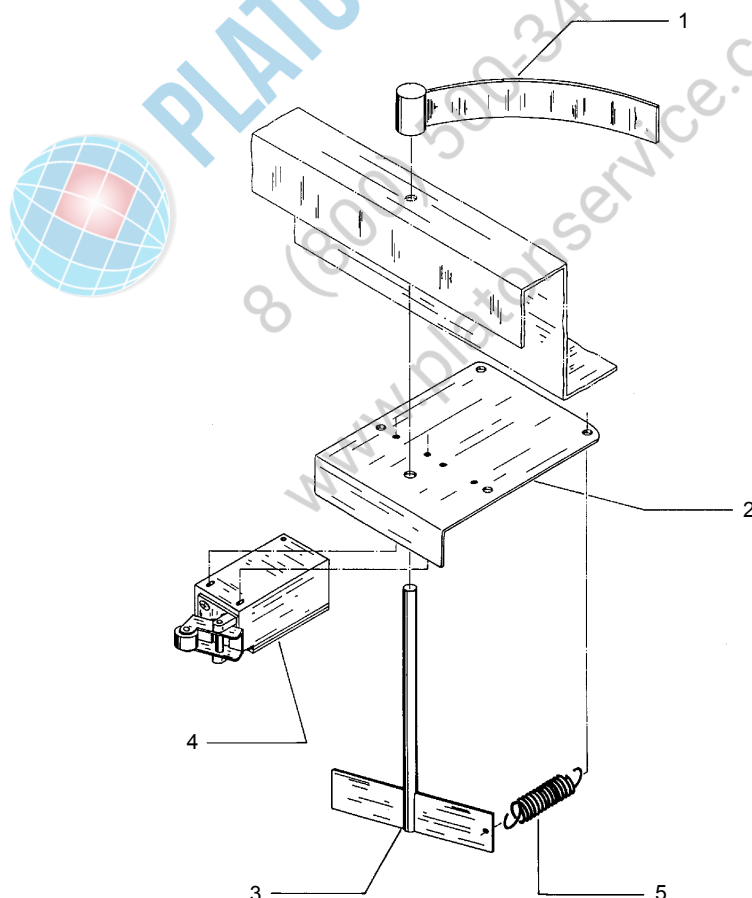

POS. 14.1 TANKHEIZUNG, ELEKTRISCH (GEWINDE)



POS. 14.1 TANK HEATING, ELECTRICAL (THREAD)

POS. 14.1 RESISTANCE DU BAC, ELECTRIQUE (FILETE)

POS.	IDENT.-NR. IDENT.-NO.	BEZEICHNUNG	DESIGNATION	DESIGNATION
1	0101165	HEIZKÖRPER 20.21523.000 90 GRAD	HEATING ELEMENT 20.21523 9 KW 220 V 90 GRAD	RESISTANCE 20.21523 9 KW 220 V 90 DEGRES
	0101178	HEIZKÖRPER V2A 20.26888.010 90 GRAD	HEATING ELEMENT 20.26888 V2A 12 KW 220 V 90 DEG.	RESISTANCE 20.26888 V2A 12 KW 220 V 90 DEGRES
2	0408020	DICHRING AFM 34 48 X 60 X 1,5 MM 1 1/2"	KLINGERIT PACKING 48 X 60 X 2 MM 1 1/2"	JOINT KLINGERIT 48 X 60 X 2 MM 1 1/2"
3	9504091	MUFFE HEIZKORPER	BUSHING F. HEATING ELEMENT	ECROU POUR RESISTANCE
4	0620315	ABDECKKAPPE KPL. K260/1/2 FŠR HEIZKORPER	CAPS COMPLETE FOR HEATING ELEMENTS	CAPUCHONS COMPLETS POUR RESISTANCE
5	0162052	VERSCHRAUBUNG	SCREWING SKINTOP ST 13,5	VISSAGE SKINTOP ST 13,5
6	0335008	SKT.-MUTTER M 5	HEXAGON NUT M 5,DIN 934 4301	ECROU A 6 PANS M 5 DIN 934,4301
7	8100331	BEFESTIGUNG F. TANKHEIZ- STAB 9 KW 86*41-76	FIXING DEVICE F. TANK HEATING ELEMENT 9 KW	FIXATION POUR THERMO- PLONGEUR DU BAC 9 KW
	8100330	BEFESTIGUNG F. TANKHEIZ- STAB 12 KW 61*41-76	FIXING DEVICE F. TANK HEATING ELEMENT 12 KW	FIXATION POUR THERMO- PLONGEUR DU BAC 12 KW

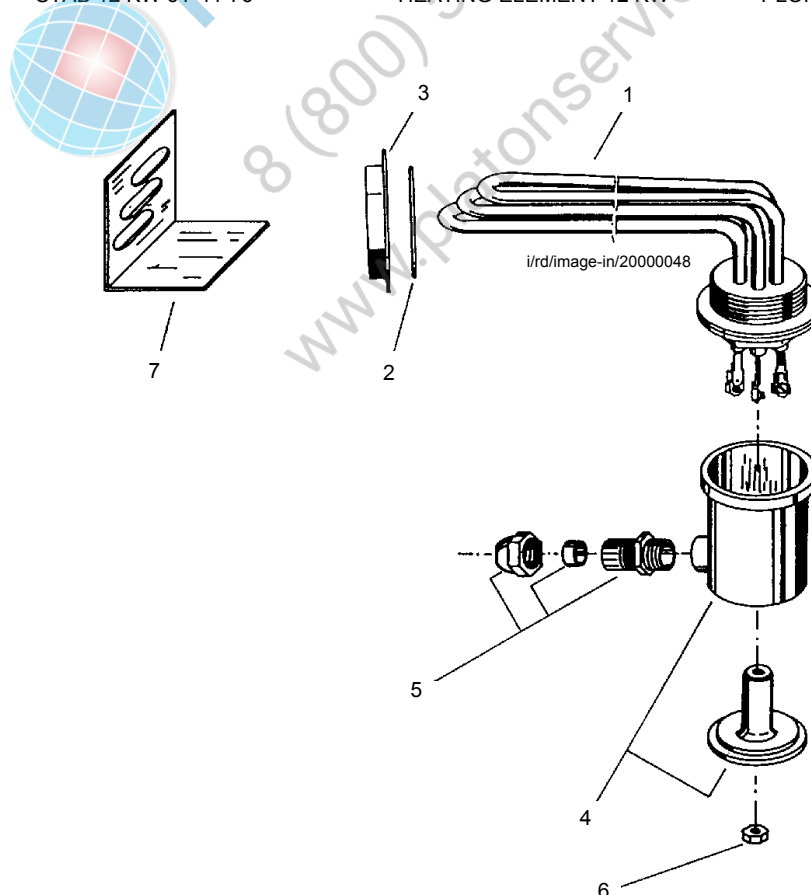

POS. 14.2 TANKHEIZUNG, ELEKTRISCH (FLANSCH)



POS. 14.2 TANK HEATING, ELECTRICAL (FLANGE)

POS. 14.2 RESISTANCE DU BAC, ELECTRIQUE (BRIDE)

POS.	IDENT.-NR. IDENT.-NO.	BEZEICHNUNG	DESIGNATION	DESIGNATION
1	0101187	HEIZKÖRPER 1GEL7C541003 90GRAD	HEATING ELEMENT 240V/8KW BENT 90 DEG. 1GEL7C541003	RESISTANCE TUBULAIRE 240V/8KW 1GEL7C541003 90GRAD
	0101186	HEIZKÖRPER 1GEL7C541001 90GRAD	HEATING ELEMENT 90 DEG. 11 KW; 240 VOLTS	RESISTANCE TUBULAIRE COUDEE 90 D. 240 V/11 KW
	0101185	HEIZKÖRPER 1GEL7C541002 90GRAD	HEATING ELEMENT 90 DEG. 15 KW / 240 VOLTS	RESISTANCE TUBULAIRE COUDEE 90 D. 240 V/15 KW
	0101196	HEIZKÖRPER 1GEL7F847 MAX. L= 700MM	HEATING ELEMENT 1GEL7F847 MAX. L= 700MM	RESISTANCE TUBULAIRE 1GEL7F847 MAX. L= 700MM
2	0401048	O-RING AP540 57X7 MM SHORE 75 GRAD	O-RING AP540 57X7 MM SHORE 75 GRAD	BAGUE-O AP540 57X7 MM SHORE 75 GRAD
3	0620316	HEIZSTABABDECKUNG 5/91 K 329	HEATING ELEMENT COVERED 5/91 K 329	ELEMENT DE CHAUFFAGE 5/91 K 329
4	0162053	VERSCHRAUBUNG	SCREWING SKINTOP ST 16	VISSAGE SKINTOP ST 16
5	0335008	SKT.-MUTTER M 5	HEXAGON NUT M 5, DIN 934 4301	ECROU A 6 PANS M 5 DIN 934,4301
6	8101245	BEFESTIGUNG TANKHEIZSTAB 60*40*96	FIXING OF TANK HEATING ELEMENT 60*40*96	FIXATION D'ELEMENT DE CHAUFFAGE 60*40*96

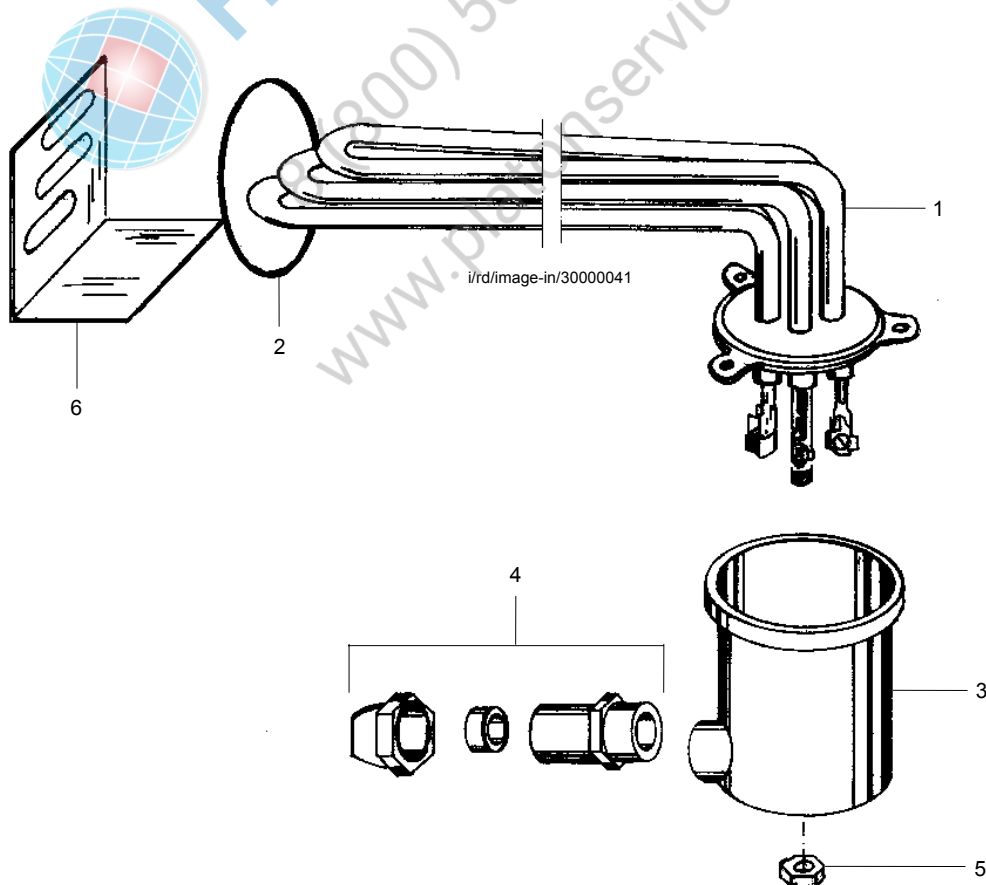

POS. 14.3 TANKHEIZSCHLANGE, NDD/HDD/PHW



POS. 14.3 TANK HEATING ELEMENT

POS. 14.3 SERPENTIN DE CHAUFFAGE

POS.	IDENT.-NR. IDENT.-NO.	BEZEICHNUNG	DESIGNATION	DESIGNATION
1	8132645	HEIZSCHLANGE 2 WINDUNGEN 95 GRAD R 3/4"	HEAT.COIL WITH 2 BENDS 95° INCLINED R 3/4"	SERP.DE CHAUFFAGE 2 TOURS 95° INCLINE R 3/4"
	8132647	HEIZSCHLANGE 3 WINDUNGEN 95 GRAD 3/4"	HEAT.COIL WITH 3 BENDS 95° INCLINED 3/4"	SERP.DE CHAUFFAGE 3 TOURS 95° INCLINE 3/4"
	8132670	HEIZSCHLANGE 4 WINDUNGEN 95 GRAD 500*205	HEAT.COIL WITH 4 BENDS 95° INCLINED 500*205	SERP.DE CHAUFFAGE 4 TOURS 95° INCLINE 3/4"

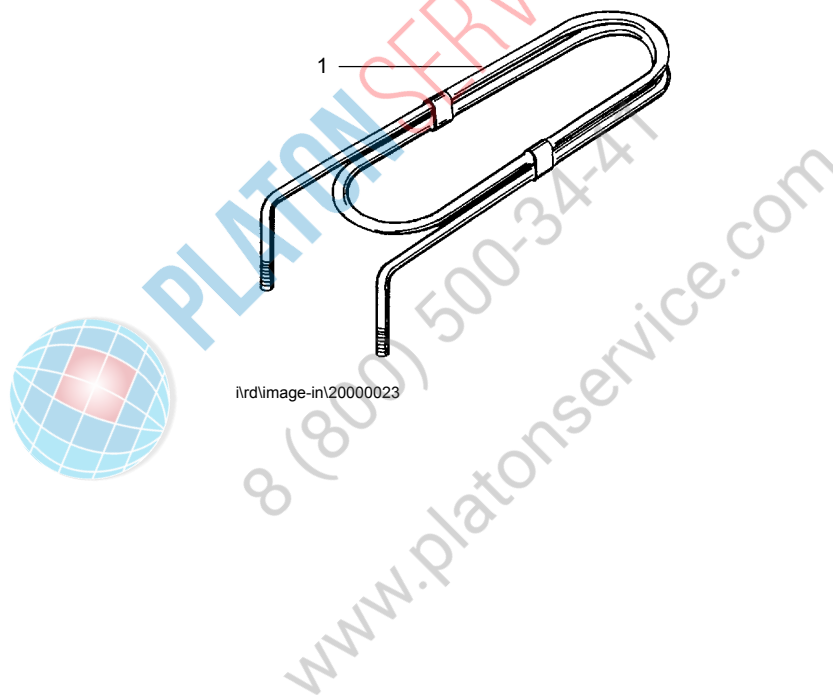

POS. 15.1 RADIALGEBLÄSE, MRL



POS. 15.1 RADIAL FAN, MRL

POS. 15.1 VENTILATEUR RADIAL, MRL

POS.	IDENT.-NR. IDENT.-NO.	BEZEICHNUNG	DESIGNATION	DESIGNATION
1	0550050	GEBLÄSE RD25S-4DW 4N.2L RADIAL 220/380V 5,0/2,9A	RADIAL BLOWER RD25S-4DW 220/380V; 5,0/2,9 A	VENTILATEUR RADIAL RD25S- 4DW; 5,0/2,9 A
	0550056	RADIALGEBLÄSE RD25S-6DW.4F.2L	BLOWER RD25S-6DW.EF.2L 230/400 V 60 HZ 0,29 KW	VENTILATEUR FC045-4DL.4F.5 265/460V 60HZ
2	0550061	VENTILATOR D07	BLOWER; LOW PRESSURE D/07 W/OUT BASE	VENTILATEUR; BASSE PRESS. D 07 SANS SOCLE
3	8100069	LÜFTERDROSSEL E-HEIZREG. 190*190	THROTTLE FOR FAN EL.HEAT. REGISTER D=190 X D=125	REDUCTEUR DE VENT. REG.DE CHAUFF. D=190 X D= 125
4	8100146	RAHMEN FÜR GEBLÄSE,SCHW.T 1.4301 440X250X30	FRAME FOR FAN 1.4301 440X250X30	CADRE DE VENTILATEUR 1.4301 440X250X30
5	8100289	HEIZREGISTER ELEKTR. 6 KW ZUSAMMENGEBAUT 2 M KABEL	HEATING REGISTER EL. 6 KW ASSEMBLED	REGISTRE DE CHAUFFAGE EL. 6 KW PRET A ETRE INSTAL.
6	8100215	ELEKTR. HEIZREGISTER 9 KW ZUSAMMENGEBAUT 2 M KABEL	HEATING REGISTER EL. 9KW ASSEMBLED	REGISTRE DE CHAUFFAGE EL. 9 KW PRET A ETRE INSTAL.
7	8100063	MANTEL F.EL.HEIZREGISTER	HEATING REGISTER EL.	REGISTRE DE CHAUFFAGE EL.
8	8100064	HEIZKOERPERBLECH	SHEET FOR HEATING ELEMENT	TOLE POUR RESISTANCE
9	0153003	ANSCHLUSSKLEMME	STRIP TERMINAL	REGLETTE DE BORNES
10	8100065	ABDECKBLECH F. HEIZREG. 392,5*101,25*30	COVER SHEET F.HEATING REG 447,5 X 128,75 X 1,25 MM	TOLE DE RECOUVREMENT P. REG.DE CHAUFF.447,5X128,7
11	0650025	GUMMI -15 01.05.5A B 230 F. NIEDERHALT.600X40X10MM	RUBBER F. HOLDING-DOWN DEVICE B230-15.01.05.5A	CAOUTCHOUC P. SUPPORT BAS B230-15.01.05.5A

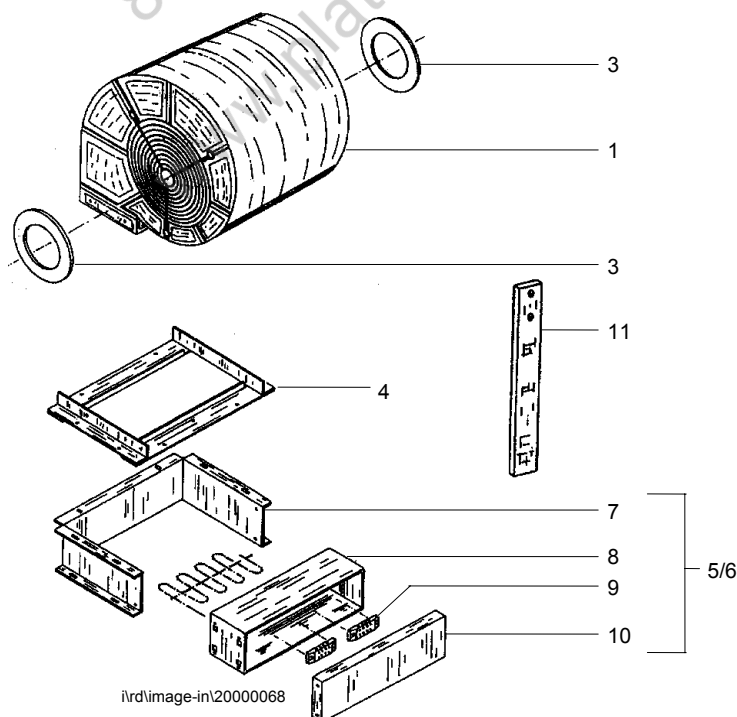

POS. 15.2/15.3 HEIZREGISTER



POS. 15.2/15.3 HEATING REGISTER

POS. 15.2/15.3 REGISTRE DE CHAUFFAGE

POS.	TEILE-NR. IDENT-NO.	BENENNUNG	DESIGNATION	DESIGNATION
------	------------------------	-----------	-------------	-------------

POS. 15.2 HEIZREGISTER, ELEKTRISCH HEATING REGISTER, ELECTRICAL REGISTRE DE CHAUFF. ELECTR.

1	0101136	HEIZKÖRPER 20.26152.000	HEATING ELEMENT 20.26152 2 KW 220 V	RESISTANCE 20.26152 2 KW 220V
2	0101135	HEIZKÖRPER 20.29651.000	HEATING ELEMENT 20.26151 3 KW 220 V	RESISTANCE 20.26151 3 KW 220V
3	0101403	HEIZK.-RING RW18 DIN 7993 FEDERSTAHL	RING 18, DIN 7993	BAGUE A 18, DIN 7993
4	8180007	U-SCHEIBE HEIZSTAB F.HEIZ REGIST. D=25XD=18,5X1	WASHER F. HEATING ELEMENT REGIST. B230KN-93.05.40.5	RONDELLE THERMOPLONGEUR P REG.DE CH. B230KN-93.05.4
5	0101401	HEIZK.-AUFNAHMEBUCHSE 40434-00.3 A.FREQUENTA	GROOVED BUSHING FROM FREQUENTA 40 434-00.3	DOILLE A RAINURES DE FREQUENTA 40 434-00.3

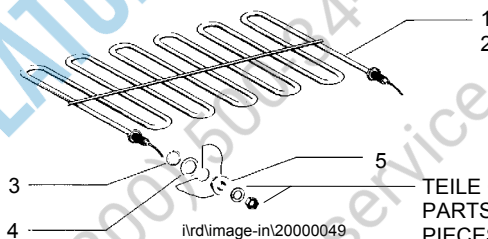

TEILE GEHÖREN ZU HEIZKÖRPER
PARTS BELONG TO HEATING ELEMENT
PIECES FONT PARTIE DE LA RESISTANCE

POS. 15.2 HEIZREGISTER, DAMPF HEATING REGISTER, STEAM REGISTRE DE CHAUFF., VAPEUR

1	0252028	HEIZREGISTER CU 22.538-1 BIS 4 BAR	HEATING REGISTER CU 22.538-1 TO 4 BAR	REGISTRE DE CHAUFFAGE CU 22.538-1 A 4 BAR
---	---------	---------------------------------------	--	--

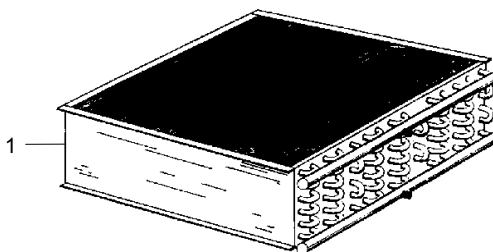

ird\image-in\20000011

**POS. 16.1/16.2/16.3 ABSPERRSCHIEBER/ABSPERRVENTIL/
SCHMUTZFÄNGER**



**POS. 16.1/16.2/16.3 STOP BAFFLE/STOP VALVE/
DIRT TRAP**

**POS. 16.1/16.2/16.3 CLAPET D'ARRET/VANNE D'ARRET/
COLLECTEUR DE BOUE**

POS.	IDENT.-NR. IDENT.-NO.	BEZEICHNUNG	DESIGNATION	DESIGNATION
------	--------------------------	-------------	-------------	-------------

POS. 16.1

ABSPERRSCHIEBER

STOP BAFFLE

CLAPET D'ARRET

1

0240022

MUFFENSCHIEBERROT/GELB
2"

MANUAL MAIN STOP VALVE 2"
LOW PRESSURE STEAM 2",

CLAPET D'ARRET MANUELLE
VAPEUR BASSE PRES.

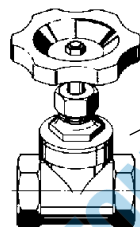

i/rd/image-in/30000069

SYSTEMDRUCK 0,3-4 BAR ÜBERDRUCK MAX. 150°C; DRUCKSTUFE PN6 2"
SYSTEM PRESSURE 0,3-4 BAR OVERPRESSURE MAX. 150°C; PRESSURE STAGE PN6 2"
PRESSION DE SYSTEME 0,3-4 BAR SURPRESSION MAX. 150°C; NIVEAU DE PRESSION PN6 2"

POS. 16.2

ABSPERRVENTIL

STOP VALVE

VANNE D'ARRET

1

0240015

PRUSSVENTIL
1"

MANUAL MAIN STOP VALVE
1", HOT WATER/HIGH

VANNE D'ARRET MANUELLE
1", EAU CHAUDE/VAPEUR

0240014

PRUSSVENTIL RG. NIRO
3/4" RG

MANUAL MAIN STOP VALVE
3/4" RED-BRASS-NIRO

VANNE D'ARRET MANUELLE
3/4" LAITON-NIRO

0240013

PRUSSVENTIL FIG. 121
1/2"

MANUAL MAIN STOP VALVE
FIG. 121 1/2"

VANNE D'ARRET MANUELLE
FIG. 121 1/2"

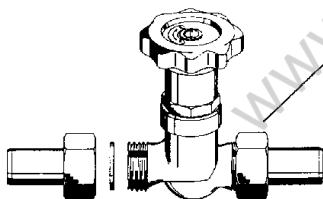

20000050

SYSTEMDRUCK 4-25 BAR ÜBERDRUCK MAX. 200°C; DRUCKSTUFE PN25
SYSTEM PRESSURE 4-25 BAR OVERPRESSURE MAX. 200°C; PRESSURE STAGE PN25
PRESSION DE SYSTEME 4-25 BAR SURPRESSION MAX. 200°C; NIVEAU DE PRESSION PN25

1

0225032

SCHMUTZFÄNGER 2826
RG 2 ZOLL

DIRT COLLECTOR LOW PRES-
SURE STEAM NW 0,52"

DECRASSEUR DE BOUE 2" VA-
PEUR BASSE PRESSION NW 0,5

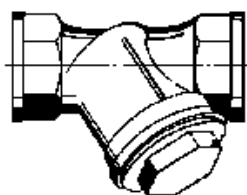

i/rd/image-in/30000066

SYSTEMDRUCK 0,3-4 BAR ÜBERDRUCK MAX. 150°C; DRUCKSTUFE PN6 2"
SYSTEM PRESSURE 0,3-4 BAR OVERPRESSURE MAX. 150°C; PRESSURE STAGE PN6 2"
PRESSION DE SYSTEME 0,3-4 BAR SURPRESSION MAX. 150°C; NIVEAU DE PRESSION PN6 2"

POS. 16.4/16.5 SCHMUTZFÄNGER/MAGNETVENTIL



POS. 16.4/16.5 DIRT TRAP/SOLENOID VALVE

POS. 16.4/16.5 COLLECTEUR DE BOUE/ELECTROVANNE

POS.	IDENT.-NR. IDENT.-NO.	BEZEICHNUNG	DESIGNATION	DESIGNATION
------	--------------------------	-------------	-------------	-------------

POS. 16.4

SCHMUTZFÄNGER

DIRT TRAP STEAM

COLLECTEUR DE BOUE

1	0225018	SCHMUTZFAENGER GG NW25 ND16	DIRT COLLECTOR HOT WATER/ HIGH PRESSURESTEAM DN 25	DECRASSEUR DE BOUE EAU CHAUDE/VAPEUR A HAUTE
2	0225014	SCHMUTZFAENGER GG NW 20 ND 16	DIRT TRAP GG NW 20 ND 16	COLLECTEUR DE BOUE GG NW 20 ND 16

**OHNE BILD
WITHOUT PICTURE
SANS ESQUISSE**

0225018 DN25

0225014 DN20

POS. 16.5

MAGNETVENTIL DAMPF

SOLENOID VALVE STEAM

ELECTROVANNE VAPEUR

3	0113100	MAGNETVENTIL 407-A-20,0- G-MS 3/4-220/50-F-000	SOLENOID VALVE 407-A-20,0 -G-BRASS 3/4-220/50-F-000	ELECTROVANNE 407-A-20,0- G-LAITON 3/4-220/50-F-000
	0113101	MAGNETVENTIL 407-A-25,0 O-G-MS1-220/50-F-000	SOLENOID VALVE 407-A-25,0 O-G-MS1-220/50-F-000	ELECTROVANNE 407-A-25,0 O-G-MS1-220/50-F-000
	0113102	MAGNETVENTIL 407-A-32-E MS 1 1/4" 220/50 -F-000	SOLENOID VALVE 407-A-32-E MS 1 1/4" 220/50 -F-000	ELECTROVANNE 407-A-32-E MS 1 1/4" 220/50 -F-000

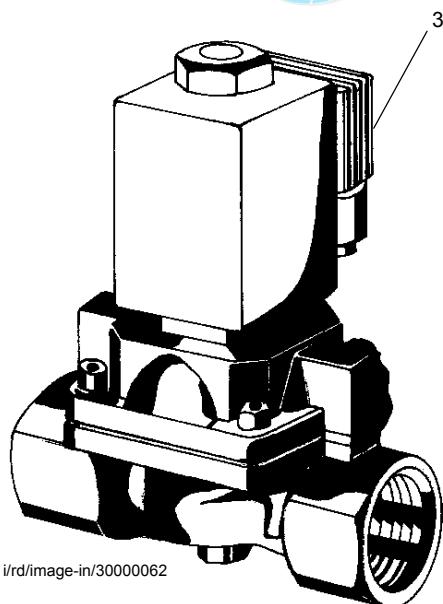

i/rd/image-in/30000062

	DURCHFLUSSMENGE FLOW QUANTITE PASSING QUANTITE DE PASSAGE	
	DAMPF STEAM VAPEUR	PHW
0113100 SYSTEMDRUCK 0,3 - 4 BAR ÜBERDRUCK ¼" 0113100 SYSTEM PRESSURE 0,3 - 4 BAR OVERPRESSURE ¼" 0113100 PRESSION DE SYSTEME 0,3 - 4 BAR SURPRESSION ¼"	50 KG/H	2500 L/H
0113101 SYSTEMDRUCK 0,3-4 BAR ÜBERDRUCK 1" 0113101 SYSTEM PRESSURE 0,3-4 BAR OVERPRESSURE 1" 0113101 PRESSION DE SYSTEME 0,3-4 BAR SURPRESSION 1"	100 KG/H	5000 L/H
0113102 SYSTEMDRUCK 0,3-4 BAR ÜBERDRUCK 1 ¼" 0113102 SYSTEM PRESSURE 0,3-4 BAR OVERPRESSURE 1 ¼" 0113102 PRESSION DE SYSTEME 0,3-4 BAR SURPRESSION 1 ¼"	150 KG/H	8000 L/H

**POS. 16.6/16.7 MENGENREGULIERVENTIL/
AUSTAUSCHSATZ STELLVENTIL**



**POS. 16.6/16.7 VOLUME COTROLING VALVE/
REPLACEMENT KIT CONTROL VALVE**

**POS. 16.6/16.7 VANNE DE REGULATION DE VOLUME/
JEU REMPLACEMENT VANNE DE CONTROL**

POS.	IDENT.-NR. IDENT.-NO.	BEZEICHNUNG	DESIGNATION	DESIGNATION
------	--------------------------	-------------	-------------	-------------

	<u>POS. 16.6</u>	<u>MENGENREGULIERVENTIL</u>	<u>VOLUME CONTROLLING VALVE</u>	<u>VANNE DE REGULATION DE VOL.</u>
1	0240025	MUFFENSCHIEBER ROT/GELB 1"	REGULATING VALVE RED/YELLOW1"	VANNE DE REGULATION ROUGE/JAUNE1"
2	0240026	MUFFENSCHIEBER ROT/GELB 3/4" RG.	REGULATING VALVE RED/ YELLOW 3/4"	VANNE DE REGULATION ROUGE/JAUNE 3/4"

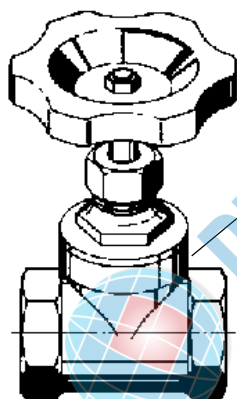

i/rd/image-in/30000069

1/2 SYSTEMDRUCK 0,3-4 BAR ÜBERDRUCK MAX. 150°C; DRUCKSTUFE PN6
SYSTEM PRESSURE 0,3-4 BAR OVERPRESSURE MAX. 150°C; PRESSURE STAGE PN6
PRESSION DE SYSTEME 0,3-4 BAR SURPRESSION MAX. 150°C; NIVEAU DE PRESSION PN6

	<u>POS. 16.7</u>	<u>AUSTAUSCHSATZ FÜR STELLVENTIL DAMPF</u>	<u>REPLACEMENT KIT FOR CONTROL VALVE STEAM</u>	<u>JEU DE REMPLACEMENT POUR VANNE DE CONTROL</u>
1	0245120	ERSATZ 8260831 STELLVENTIL ND16NW32 5/4"	REPLACEMENT 8260831 CONTROL VALVE 5/4"	REPLACEMENT 8260831 VANNE DE CONTROL 5/4"

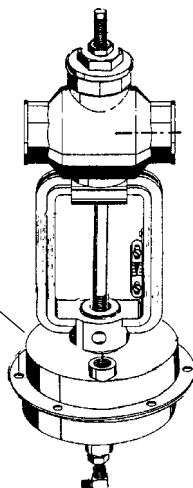

i/rd/image-in/20000051

POS. 16.8A STELLVENTIL DAMPF



POS. 16.8A CONTROL VALVE STEAM

POS. 16.8A VANNE DE CONTROL VAPEUR

POS.	IDENT.-NR. IDENT.-NO.	BEZEICHNUNG	DESIGNATION	DESIGNATION
1	0245100	STELLVENTIL PN 16 DN 20 3.203 271HDD	CONTROL VALVE DN 20 ,PN16 UP TO 13 BARS, 180 C	VANNE DE CONTROLE DN 20, PN 16 JUSQU'A 13 BARS
2	0245140	STELLVENTIL STAHLGUSS NW 20 PN 25 T.3.203	CONTROL VALVE DN 20,PN 25 FROM 13 BARS ON	VANNE DE CONTROLE DN 20 PN 25 A PARTIR DE 13 BARS
3	0245121	STEUERV.-DRUCKFEDER	SPRING	RESSORT
4	0245102	STEUERV.-MEMBRANE 2002 0520-0497 TYP 203	DIAPHRAGM 2002 TYPE 203	MEMBRANE 2002 TYPE 203
5	0245103	STEUERV.-SPANNBAND TYP203 271/80 8395-0157 F.ANTR.	CLIPS FOR DRIVE 271/80	COLLIER POUR ENTRAINEMENT 271/80
6	0245114	STEUERV.-HUB-BEGRENZUNG KPL.	STROKE LIMITOR COMPL.	LIMITEUR D'ELEVATION COMPLET
7	0245115	STEUERV.-DICHRING	PACKING RING	BAGUE JOINT
8	0245113	STEUERV.-DICHRING FLACH 32 X 26 X 2 MM	FLAT PACKING RING D=32 X D=26 X2	JOINT PLAT D= 32 X D=26 X 2
9	0301036	SKT.-SCHRAUBE M12X50	HEXAGON SCREW FE M 12 X 50, DIN 601	VIS A 6 PANS FE M 12 X 50 DIN 601
10	0335038	SKT.-MUTTER M 12	HEXAGON NUT FE M 12 DIN 934	ECROU A 6 PANS FE M 12 DIN 934
11	8480007	DICHTUNG F.DAMPFSCHLANGE D=60XD=20X3 IT400	PACKING B 230 KN-72, 20.01.5	JOINT B 230 KN-72.20.01.5
12	0245108	STEUERV.-DICHRING FLACH 40 X 52 X 1 MM	FLAT PACKING RING 40 X 52 X 1,TYPE 203	JOINT BAGUE 40 X 52 X 1 TYPE 203
13	0245111	STEUERV.-DICHTUNG 38 X 30 X 1 MM	SEAL D= 38 X D=30 X 1	JOINT D=38 X D=30 X 1
14	0245110	STEUERV.-BALG	SKIN RUBBER BALLOWS	PEAU SOUFFLET
15	0245109	STEUERV.-PNEUMATISCHER ANTRIEB FÜR 0245100	PRESSURE SWITCH	INTERRUPTEUR DE PRES- SION
16	0245121	STEUERV.-DRUCKFEDER	SPRING	RESSORT
17	0245102	STEUERV.-MEMBRANE 2002 0520-0497 TYP 203	DIAPHRAGM 2002 TYPE 203	MEMBRANE 2002 TYPE 203
18	0245103	STEUERV.-SPANNBAND TYP203 271/80 8395-0157 F.ANTR.	CLIPS FOR DRIVE 271/80	COLLIER POUR ENTRAINEMENT 271/80
19	0210001	WINKEL MS 1/4 ZOLL	ANGLE BRASS 1/4"	ANGLE LAITON 1/4"
20	0730401	ROHR RINGE	COPPER TUBE RINGS D=6 X 1 MM	TUYAU EN CUIVRE EN BAGUES D= 6 X 1 MM
21	0245120	ERSATZ 8260831 STELLVENTIL ND16NW32 5/4"	REPLACEMENT 8260831 CONTROL VALVE 5/4"	REPLACEMENT 8260831 VANNE DE CONTROLE 5/4"

POS. 16.8A STELLVENTIL DAMPF



POS. 16.8A CONTROL VALVE STEAM

POS. 16.8A VANNE DE CONTROL VAPEUR

POS.	IDENT.-NR. IDENT.-NO.	BEZEICHNUNG	DESIGNATION	DESIGNATION
------	--------------------------	-------------	-------------	-------------

0245100
 SYSTEMDRUCK 4-9 BAR ÜBERDRUCK MAX. 180°C; DRUCKSTUFE PN 16 DN20
 SYSTEM PRESSURE 4-9 BAR OVERPRESSURE MAX. 180°C; PRESSURE STAGE PN 16 DN20
 PRESSION DE SYSTEME 4-9 BAR SURPRESSION MAX. 180°C; NIVEAU DE PRESSION PN 16 DN20

0245140
 SYSTEMDRUCK 9-25 BAR ÜBERDRUCK MAX. 200°C; DRUCKSTUFE PN 25 DN20
 SYSTEM PRESSURE 9-25 BAR OVERPRESSURE MAX. 200°C; PRESSURE STAGE PN 25 DN20
 PRESSION DE SYSTEME 9-25 BAR SURPRESSION MAX. 200°C; NIVEAU DE PRESSION PN 25 DN20

	DURCHFLUSSMENGE FLOW QUANTITY PASSING QUANTITE DE PASSAGE	
	DAMPF STEAM VAPEUR	PHW
LG.-NR. 0245100	250 KG/H	3000 L/H
LG.-NR. 0245140	500 KG/H	3000 L/H

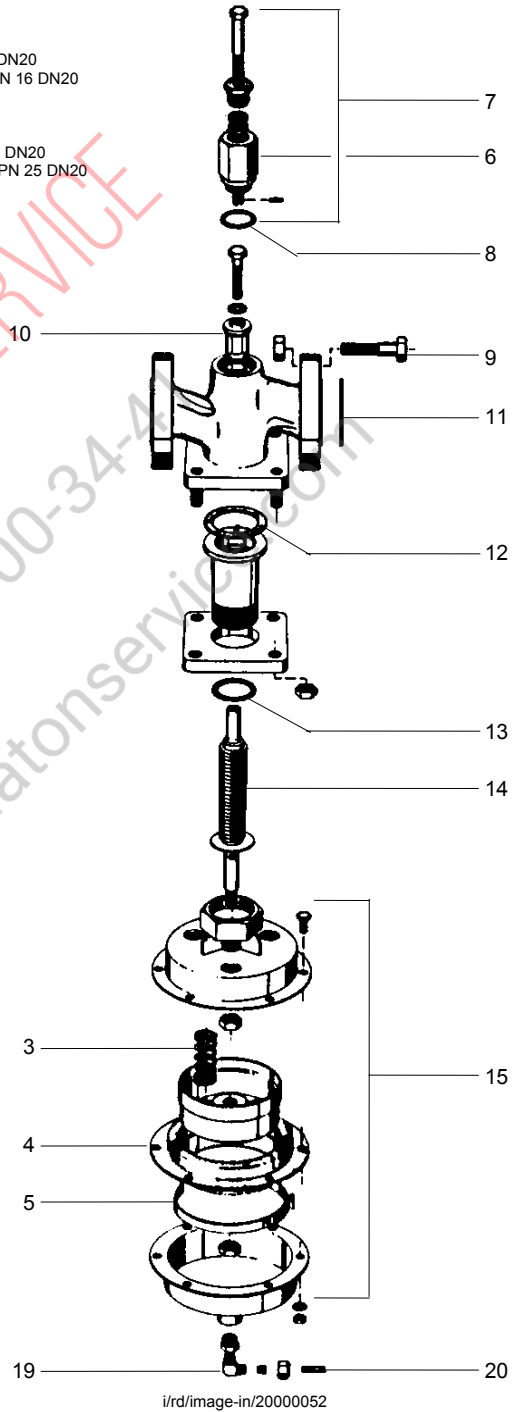

iird/image-in/20000052

POS. 16.8B ERSATZ FÜR POSITION 18A



POS. 16.8B REPLACEMENT FOR POSITION 18A

POS. 16.8B REPLACEMENT POUR POSITION 18A

POS.	IDENT.-NR. IDENT.-NO.	BEZEICHNUNG	DESIGNATION	DESIGNATION
1	0113102	MAGNETVENTIL 407-A-32-E MS 1 1/4" 220/50 -F-000	SOLENOID VALVE 407-A-32-E MS 1 1/4" 220/50 -F-000	ELECTROVANNE 407-A-32-E MS 1 1/4" 220/50 -F-000
2	0240027	MUFFENSCHIEBER ROT/GELB 5/4" RG.	REGULATION VALVE RED/YELL 5/4" RED BRASS	CLAPET ROUGE/JAUNE 5/4" RG
3	0206012	VERSCHRAUBUNG 331 G+F R 1 1/4 ZOLL I.A. SCHWARZ	SCREWING 331 G+F 1 1/4" INSIDE/OUTSIDE BLACK	VISSERIE 331 G + F R 1 1/4" I.A. NOIR
4	0408104	DICHTUNG 42X55 GYLON 5/4"	FLAT SEALING 1,6 GYLON 5/4"	JOINT PLAT 1,6 GYLON 5/4"
5	8660126	GEWINDENIPPEL R=1 1/4"X31 ST 37	THREADED NIPPLE R=1 1/4"X31 ST 37	RACCORD FILETE R=1 1/4"X31 ST 37

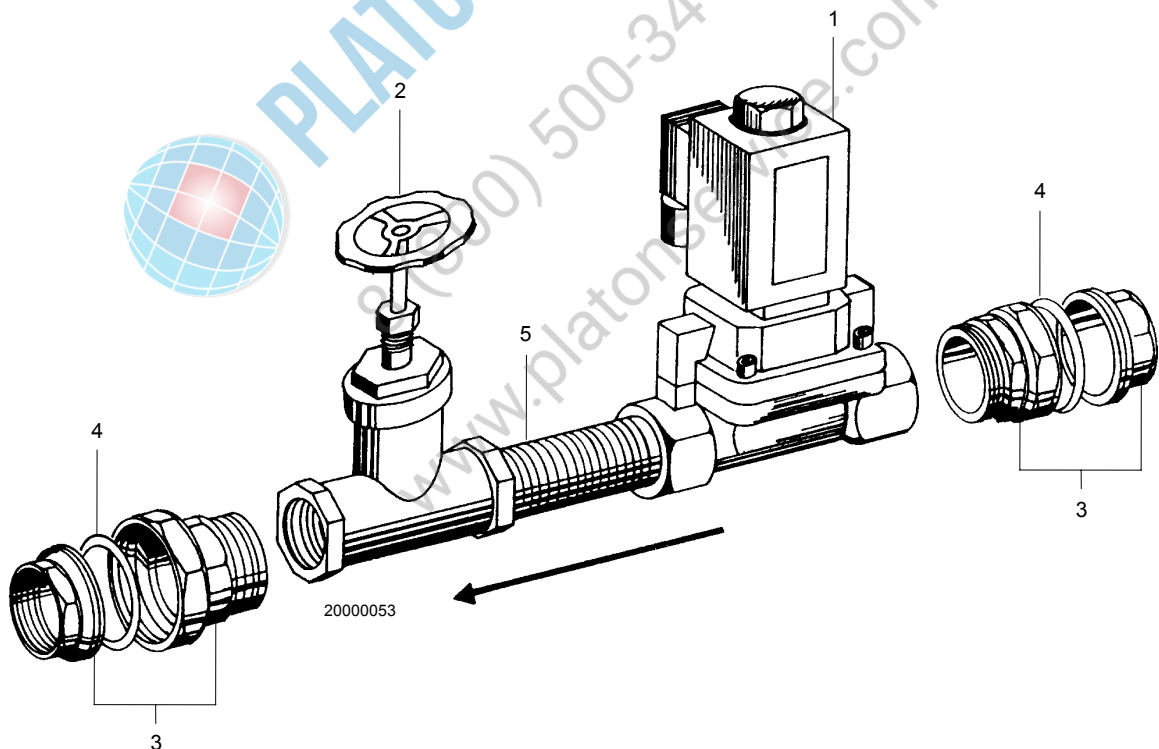

POS. 16.9 VORSTEUERVENTIL ZU POSITION 16.8A



POS. 16.9 PRECONTROL VALVE FOR POSITION 16.8A

POS. 16.9 VANNE PILOTE POUR POSITION 16.8A

POS.	IDENT.-NR. IDENT.-NO.	BEZEICHNUNG	DESIGNATION	DESIGNATION
1	0113009	MAGNETVENTIL Z.VORSTEUERN GUL 2/00 NK 1/8" 220 V	PRECONTROL VALVE GUL 2-00 NK 3/8"	VANNE PILOTE COMP. EAU CHAUDE, VAPEUR HAUTE+BAS.
2	0233036	SCHNECKENGWINDESCHELLE SX 9 10-16 C7-W2	NORMA-BINDER 12 48 03 00 13	BORNE NORMA 12 48 03 00 13
3	0630216	SCHLAUCH TRANSP. 6 X 3 MM PVC MIT GEWEBE	TRANSPARENT PVC HOSE D= 6 X 3 MM	TUYAU FLEXIBLE TRANSPA- RENT PVC D=6 X 3 MM
4	0206053	ECK-ANSCHLUSS-STUECK MS58 R 1/8 ZOLL NR.60188273	CORNER CONNec. PIECE R1/8"NO. 4320 135 MS 58	PIECE EN ANGLE DE CONNE- XION R 1/8" NO. 4320 135
5	0113029	STECKBUECHSE HIRSCHMANN GDM 2009+DICHTUNG GDM 3-7	PLUG-IN BUSH 1513985 F. VHRF AND PRECON. VALVE	FICHE DE CONNEXION
6	0113005	MAGNETSPULE 13-30 1629040 W.NR. 5761 DB GUL2/F00NK	COIL FN 86 GUL 2/00 N ART.NO. 1510938	BOBINE FN 86, NO. 151 0939 GUL 2/00 N
7	0206019	VERSCHR. GE 6 -LR 1/8"	ERMETRO-SCREWING 1/8" A 26 R	VISSAGE ERMETO 1/8" A 26 R
8	0730401	ROHR RINGE	COPPER TUBE RINGS D=6 X 1 MM	TUYAU EN CUIVRE EN BAGUES D= 6 X 1 MM

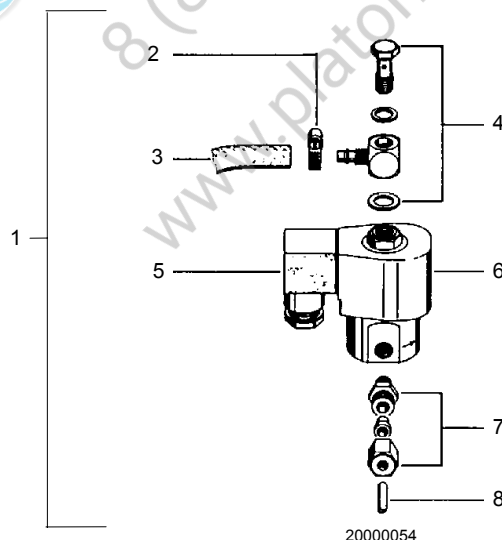

20000054

POS. 16.10 KONDENSATABLEITER



POS. 16.10 STEAM TRAP

POS. 16.10 SEPARATEUR DE VAPEUR

POS.	IDENT.-NR. IDENT.-NO.	BEZEICHNUNG	DESIGNATION	DESIGNATION
------	--------------------------	-------------	-------------	-------------

	<u>POS. 16.10</u>	<u>KONDENSATABLEITER</u>	<u>STEAM TRAP</u>	<u>SEPARATEUR DE VAPEUR</u>
1	0232024	KONDENSATABLEITER NW 15 1/2" TD3 3-3 LS	STEAM TRAP DN15/PN 16HIGH PRESS.STEAM 2-16 BARS	SEPAR.D.VAPEUR DN15/PN 16 VAPEUR HAUTE PRESS.2-16BA

1 SYSTEMDRUCK 4-25 BAR ÜBERDRUCK MAX. 200°C; DRUCKSTUFE PN6 R1/2"
SYSTEM PRESSURE 4-25 BAR OVERPRESSURE MAX. 200°C; PRESSURE STAGE PN6 R1/2"
PRESSION DE SYSTEME 4-25 BAR SURPRESSION MAX. 200°C; NIVEAU DE PRESSION PN6 R1/2"

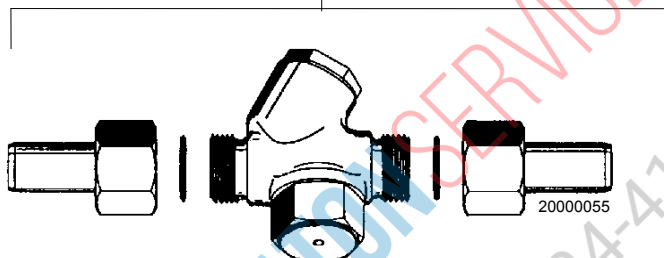

	<u>POS. 16.11</u>	<u>KONDENSATABLEITER</u>	<u>STEAM TRAP</u>	<u>SEPARATEUR DE VAPEUR</u>
1	0232031	KONDENSATABLEITER BPT7S 1/2" STEUERELEMENT 6K	STEAM TRAP BPT7S1/2" CONTROL ELEMENT 6K	SEPARATEUR DE VAPEUR BPT7S 1/2" ELEMENT DE COMMANDE

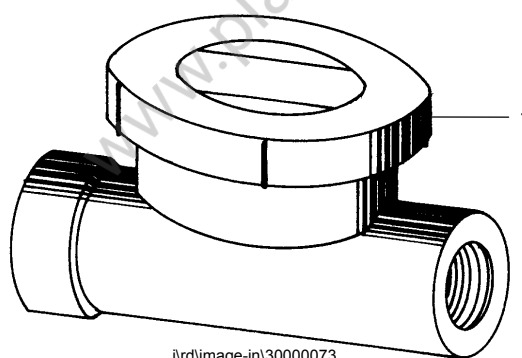

POS. 17.1/17.2 DURCHFLUßWÄCHTER / MAGNETSCHALTER



POS. 17.1/17.2 FLOW CONTROL / MAGNETIC SWITCH

POS. 17.1/17.2 DEBIT METRE / INTERRUPTEUR AIMANT

POS.	IDENT.-NR. IDENT.-NO.	BEZEICHNUNG	DESIGNATION	DESIGNATION
------	--------------------------	-------------	-------------	-------------

ALLE HIR NICHT AUFGEFÜHRTE ELEKTRISCHE BAUTEILE FINDEN SIE IN DER STÜCKLISTE DES MASCHINENSCHALTPLANES

ALL ELECTRICAL PARTS NOT STATED HEREIN ARE LISTED IN THE ELECTRICAL SCHEME OF THE MACHINE

TOUTES LES PIECES ELECTR. ICI NON-MENTIONNEES SONT INDIQUEES DANS LA LISTE DU SCHEMA ELECTR. DE LA MACHINE

<u>POS. 17.1</u>	<u>DURCHFLUßWÄCHTER</u>	<u>FLOW CONTROL</u>	<u>DEBIT METRE</u>
1	8101565 UMBAUSATZ DRUCKSCHALTER AUF DRUCHFLUÁWÄCHTER	MODIFICATION UNIT; PRESS. SWITCH TO PRESS. CONTROL	KIT TRANSF. PRESSOSTAT EN CONTROL. DE DEBIT D'EAU

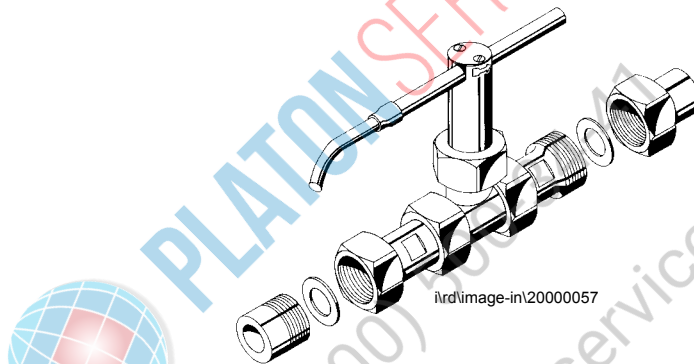

1	0130060 AUSTAUSCHWAECHTER KPL. 7305277720	DRY RUN PROTECTION CPL. 7305277720	PROTECTEUR DE CHAUFFAGE A SEC CPL. 7305277720
---	---	---------------------------------------	--

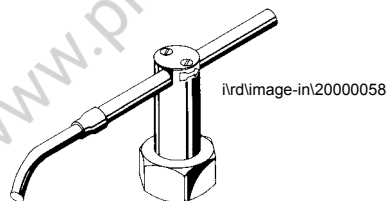

<u>POS. 17.2</u>	<u>MAGNETSCHALTER</u>	<u>MAGNETIC SWITCH</u>	<u>INTERRUPTEUR AIMANT</u>
1	0122024 ENDTASTER MAK-1212 F+VDR 6314212439 3M KABEL IP67	FINAL SWITCH MAK-1212 F W/CABLE 3 MTRS	INTERRUPTEUR FINAL MAK- 1212 F+RC AVEC CABLE 3 M
	0122021 ENDSCHALTER 6417312307 MAK-1213M2 VDR	FINAL SWITCH MAK-1213 WITH 2 M CABLE	INTER.FINAL MAK-1213 M+RC 6417312307 AVEC 2M CABLE
	0122022 GRENZTASTER MAK-1212F+VDR 6314212217 MIT 1M KABEL	LIMIT SWITCH MAK-1212F+RC 6314212217 WITH CABLE 1M	INTER.FIN COURSE MAK-1212 F+RC 6314212217 1M CABLE

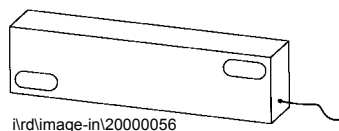

POS. 17.3/17.4 NÄHERUNGSSCHALTER FÜR DEMI/THERMOSTAT



POS. 17.3/17.4 PROXIMITY SWITCH FOR DEMI/THERMOSTAT

POS. 17.3/17.4 DETECTEUR DE PROXIMITE P. DEMI/THERMOSTAT

POS.	IDENT.-NR. IDENT.-NO.	BEZEICHNUNG	DESIGNATION	DESIGNATION
	<u>POS. 17.3</u>	<u>NÄHERUNGSSCHALTER FÜR DEMI</u>	<u>PROXIMITY SWITCH FOR DEMI</u>	<u>DETECTEUR DE PROXIMITE POUR DEMI</u>
1	0122055	NAEHRUNGSSCHALTER D=77 MM 6604566868KIN-R77TS/035-3	FINAL SWITCH D=77 MM KL-2520/035-3 6604566868	DETECTEUR DE PROXIMITE D=77
2	8101639	ABDECKUNG NÄHERUNGSSCHAL- TER PPH D=83*D=76,7*43	COVER FOR PROXIMITY SWITCH PPH D=83*D=76,7*43	RECOUVREMENT P. DETECTEUR DE PROXIMITE PPH D=83*D=76,7*43

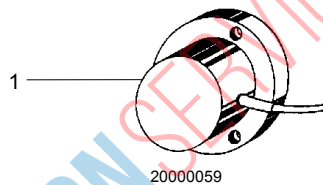

POS. 17.4

THERMOSTAT

THERMOSTAT

THERMOSTAT

1	0108041	TERMOSTAT TYP 716 RU-1519 KAPILLARROHRLAENGE 3100MM	THERMOSTAT TYPE 716 RU 1519 PROBE LENGTH 3100	THERMOSTAT TYPE 716 RU 1519 PROBE LONGUEUR 3100
---	---------	--	--	--

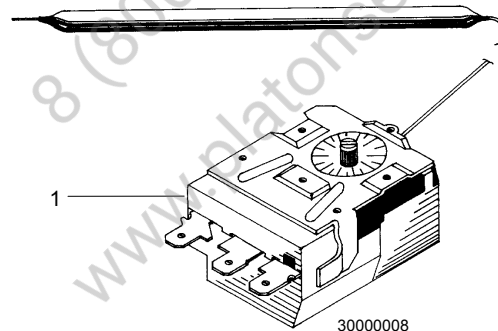

POS. 17.5 MAGNETSCHALTER



POS. 17.5 MAGNETIC SWITCH

POS. 17.5 INTERRUPTEUR AIMANT

POS.	IDENT.-NR. IDENT.-NO.	BEZEICHNUNG	DESIGNATION	DESIGNATION
------	--------------------------	-------------	-------------	-------------

1	0122051	SCHALTER 6420245208 MAK 4522-Y	SWITCH 6420245208 MAK 4522-Y	INTERRUPTEUR 6420245208 MAK 4522-Y
---	---------	-----------------------------------	---------------------------------	---------------------------------------

2	0122052	SCHALTER 9320245034 MAK4522-Y 5M	SWITCH 9320245034 MAK4522-Y 5M	INTERRUPTEUR 9320245034 MAK4522-Y 5M
---	---------	-------------------------------------	-----------------------------------	---

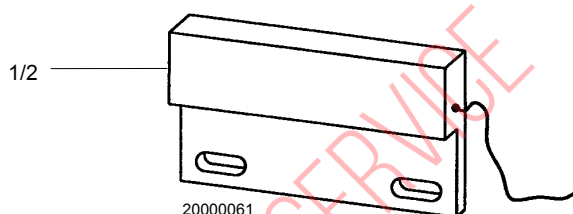

3	0122050	ENDSCHALTER 6317344605 MAK4413M-6 VDR	FINAL SWITCH -VDR 3M CABLE MAK 4413M-3	INTERRUPTEUR FINAL 4413M-3-VDR 3M DE CABLE MAK
---	---------	--	--	--

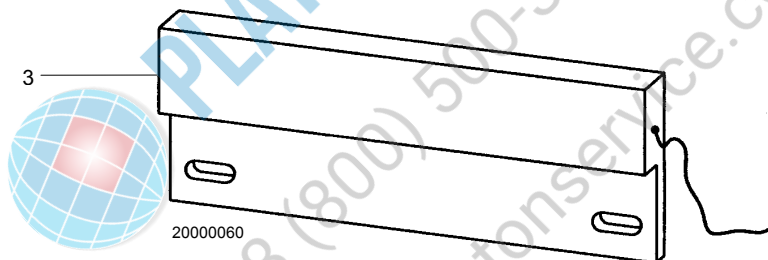

4	0122037	MAGNETSCHALTER 6410211418 MAK-1112	SOLENOID SWITCH 6410211418 MAK-1112	INTERRUPTEUR MAGNETIQUE 6410211418 MAK-1112
---	---------	---------------------------------------	--	--

5	0122033	MAGNETSCHALTER MAK-1112-2	SOLENOID SWITCH MAK-1112-2	INTERRUPTEUR MAGNETIQUE MAK-1112-2
---	---------	------------------------------	-------------------------------	---------------------------------------

6	0122057	MAGNETSCHALTER 6411211384 MAK 1112-B-5	SOLENOID SWITCH 6411211384 MAK 1112-B-5	INTERRUPTEUR MAGNETIQUE 6411211384 MAK 1112-B-5
---	---------	---	--	--

7	0122053	SCHALTER 6310311615 MAK 1113-1	SWITCH 631.0311.615 MAK 1113-1	INTERRUPTEUR 631.0311.615 MAK 1113-1
---	---------	-----------------------------------	--------------------------------------	--

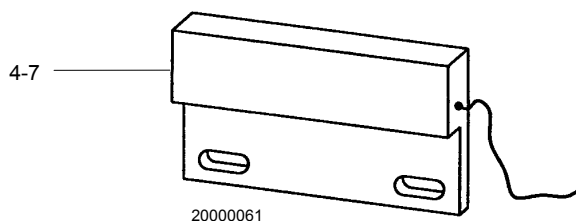

POS. 18.1 / 18.2 DRUCKERHÖHUNGSPUMPE / FERNTHERMOMETER**POS. 18.1 / 18.2 BOOSTER PUMP / TEMPERATUR GAUGE****POS. 18.1 / 18.2 SURPRESSEUR / TELETHERMOMETRE**

POS.	IDENT.-NR. IDENT.-NO.	BEZEICHNUNG	DESIGNATION	DESIGNATION
	POS. 18.1	DRUCKERHÖHUNGSPUMPE	BOOSTER PUMP	SURPRESSEUR
1	0535051	KREISELPUMPE MULTIBLOC CA4-24	CENTRIFUGAL PUMP MULTI-BLOC C4-25E 1-PHASE 220V	POMPE CENTRIFUGE MULTI-BLOC C4-25E 1-PHASE 220V
2	0535053	JETPUMPE JP5 220/240 380/415 VOLTS	BOOSTER PUMP JP5 JETPUMP380/415 VOLTS	POMPE "JET" JP5 220-240V/380-415 V
3	0535057	PUMPE CALPEDA NT61 BRONZE 230/400V 50HZ 0,33KW	PUMP CALPEDA NT61 230/400V 50HZ 0,33KW	POMPE CALPEDA NT61 230/400V 50HZ 0,33KW
4	0535056	PUMPE CALPEDA NTM61 230V 50HZ 0,33KW	PUMP CALPEDA NTM61 230V 50HZ 0,33KW	POMPE CALPEDA NTM61 230V 50HZ 0,33KW

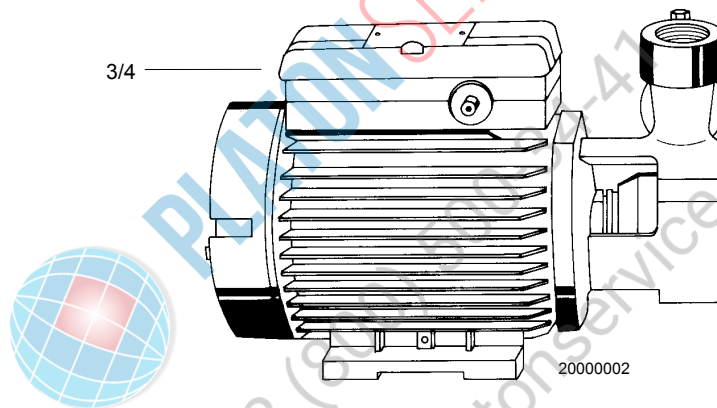

	POS. 18.1	FERNTHERMOMETER	TEMPERATURE GAUGE	TELETHERMOMETRE
1	0465007	FERNTHERMOMETER IFC 52 K 1500 MM	TEMPERATURE GAUGE D=52 CAPILLARY LENGTH 1.500 MM	TELETHERMOMETRE D=52 MM LONGUEUR DU FIL 1.500 MM
2	8104027	TAUCHHÜLSE SW19X54 4305	BUSHING TEMPERATURE GAUGE D=20X54 4305 B230KN-30.01	TUYAU PLONGEUR POUR TELE-THERMOMETRE 4301, B 230KN
3	8660045	MUTTER R 3/8" MS SW 22 X8	HEXAGON NUT R=3/8" SW22X8 BRASS N11-11.5	ECROU A SIX PINS R=3/8" SW22X8 LAITON N11-11.5
4	8660106	SKT-MUTTER R=3/8" SW22X8 4301	SKT NUT R=3/8" SW 22X8 4301 N11-11.5	ECROU A SIX PINS R=3/8" SW 22X8; 4301; N11-11.5

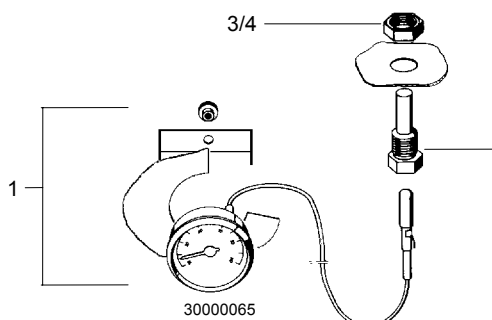

2
TAUCHHÜLSE MS VERNICKELT GEHÖRT ZUM LIEFERUMFANG DES THERMOMETERS
DIVING BUSH NICKLED-PLATED BELONGING TO SCOPE OF DELIVERY OF THERMOSTAT
DOUILLE D'IMERSION MS, NICKELE, FAIT PARTIE DE LA LIVREISON DU THERMOSTAT

POS. 18.3 / 18.4 THERMOSTAT / MASCHINENSTOLLEN



POS. 18.3 / 18.4 THERMOSTAT / FEET OF MACHINE

POS. 18.3 / 18.4 THERMOSTAT / PIEDS DE MACHINE

POS.	IDENT.-NR. IDENT.-NO.	BEZEICHNUNG	DESIGNATION	DESIGNATION
------	--------------------------	-------------	-------------	-------------

<u>POS. 18.3</u>	<u>THERMOSTAT</u>	<u>THERMOSTAT</u>	<u>THERMOSTAT</u>
1	0108005 TEMPERATURREGLER KURZ TYP SB 19.01 OHNE TAUCH-	TANK TEMPERATURE CONTROL TYPE SP 19.01	THERMOSTAT D.SURCHAUFFEUR AVEC TUYAU PLONGEUR
2	8400074 TAUCHHÜLSE KPL L=110 TANKTHERMOSTAT SOPAC	PLUNGER F. TEMP. CONTROL TANK TEMP.GAUGE SOPAC 110	DOUILLE B230KN-30.01.01.5 THERMOSTAT DU BAC SOPAC
3	0408006 DICHRING AFM 34 21X30X1,5 MM	TENSION RING KLINGERIT 21 X 30 X 2 MM	BAGUE DE TENSION KLINGER. 21 X 30 X 2 MM
4	8660046 SKT-MUTTER R=1/2" SW27X8 MS	NUT 1/2" 27X10; N11-12,5	ECROU 1/2" 27X10

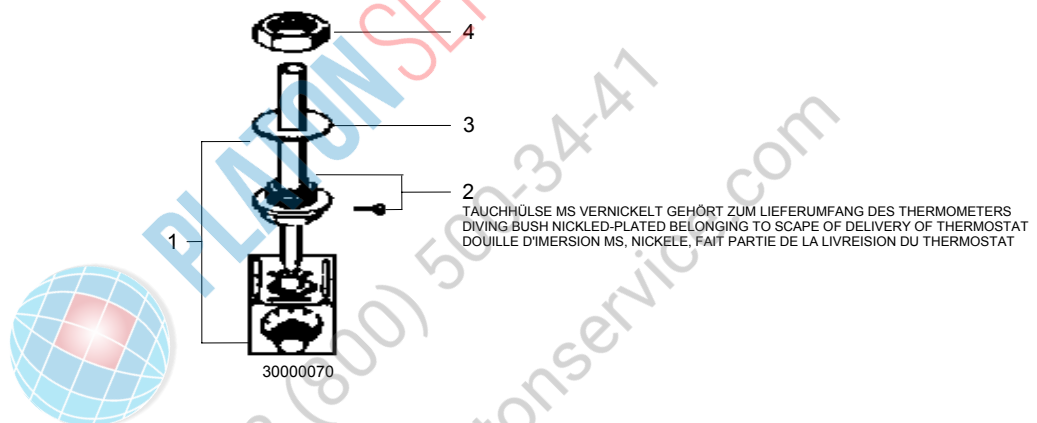

<u>POS. 18.4</u>	<u>MASCHINENSTOLLEN</u>	<u>FEET OF MACHINE</u>	<u>PIEDS DE MACHINE</u>
1	0621003 TISCHSTOLLEN K429/1 UND K429/2	TABLE FEET, 2 PARTS K 220/221	PIEDS DE TABLE 2 PARTIES, K 220/221
2	0460030 STELLFUSS NIRO 1015-4003-1144	CAMLOCK FOOT 1015-4003-1144	PIED CAMLOCK 1015-4003-1144

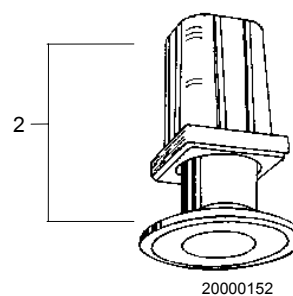
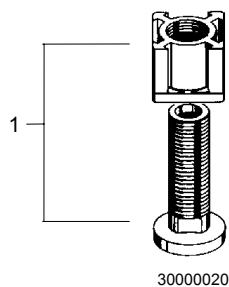

POS. 18.5 SCHWIMMER FÜR NIVEAUREGLER



POS. 18.5 FLOAT FOR LEVEL REGULATOR

POS. 18.5 FLOTTEUR POUR REGLAGE DE NIVEAU

POS.	IDENT.-NR. IDENT.-NO.	BEZEICHNUNG	DESIGNATION	DESIGNATION
1	0620351	SCHWIMMER K 343	FLOAT, PLASTIC K 343	FLOTTEUR K 343
2	8101276	SCHWIMMERFÜHRUNG 177 X 45 X 44	FLOAT GUIDE 177 X 45 X 44	GUIDAGE POUR FLOTTEUR 177 X 45 X 44

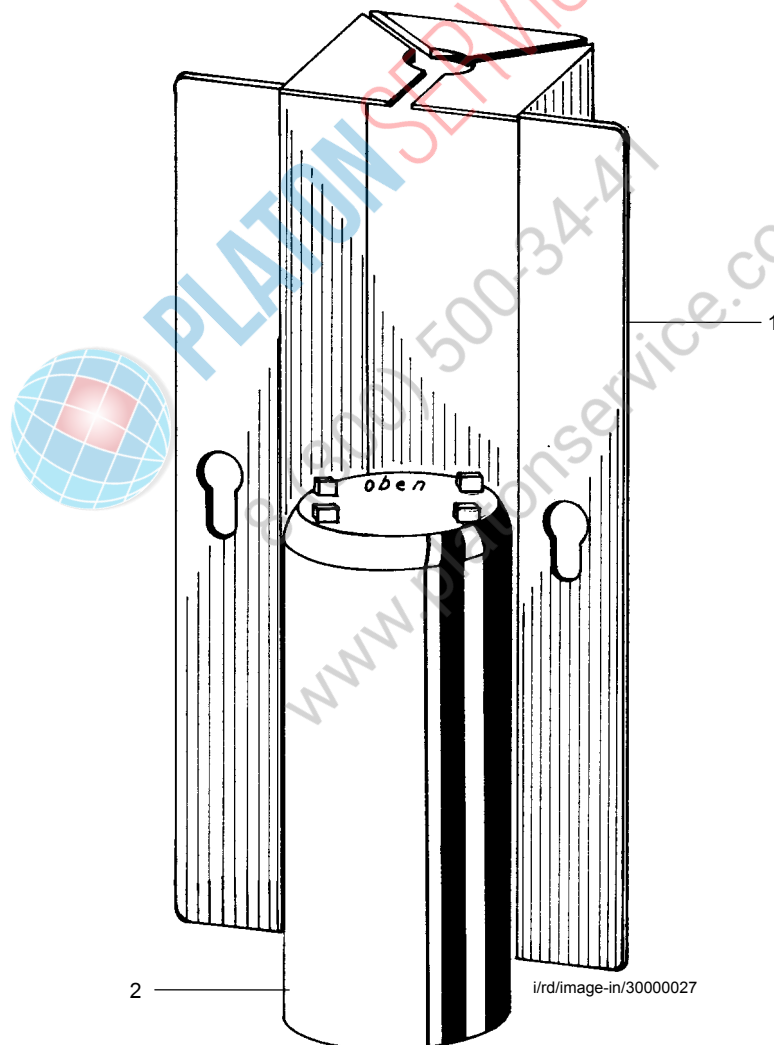

POS. 18.6 FROSTSCHUTZWÄCHTER



POS. 18.6 ANTI-FREEZE PROTECTION

POS. 18.6 PROTECTEUR ANTI-GEL

POS.	IDENT.-NR. IDENT.-NO.	BEZEICHNUNG	DESIGNATION	DESIGNATION
------	--------------------------	-------------	-------------	-------------

1	0108032	TEMP.REGLER FROTSCHUTZ TA 95.02 -20 BIS +60 GRAD	THERMO CONTROL -9 TO +15 DEGR. C.	PROTECTION ANTI-GEL - 9 A + 15 GRAD
2	0530200	MOTOR FÜR FROTSCHUTZKLAPPE	SERVOMOTOR FOR FROST ROTECTION	MOTEUR P. CLAPET ANTI-GEL

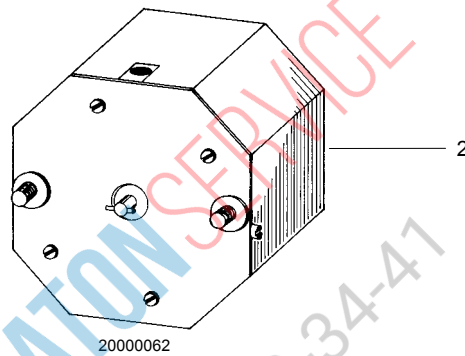

PLATON SERVICE
8 (800) 500-34-47
www.platonservice.com

POS. 18.7 WASCHLAUGENZYKLON



POS. 18.7 WASH WATER CYCLONE

POS. 18.7 CYCLONE D'EAU DE LAVAGE

POS.	IDENT.-NR. IDENT.-NO.	BEZEICHNUNG	DESIGNATION	DESIGNATION
1	8600007	ZYKLONGEHÄUSE KPL. EINGANG LINKS	CYCLONE HOUSING COMPL. ENTRY LEFT HAND Z20-01.00	CORPS CYCLONE COMPL. ENTREE A GAUCHE Z20-01.00
2	8600008	ZYKLONGEHÄUSE KPL. EINGANG RECHTS	CYCLONE HOUSING COMPL. ENTRY RIGHT H. Z20-01.00	CORPS CYCLONE COMPL. ENTREE A DROITE Z20-01.00
3	0217432	GUMMIDICHTUNG 24 X 14 X 2 MM	RUBBER PACKING 25 X 14 X 2 MM	JOINT EN CAOUTCHOUC 25 X 14 X 2 MM
4	8000018	SCHLAUCHANLSCHUSS/ZYKLON D=22,8X42 PPH	HOSE CONNECTION/CYCLONE D=22,8X42 PPH Z20-02.00	CONNEXION TUYAU/CYCLONE D=22,8X42 PPH Z20.02.00
5	0621076	UEBERWURFMUTTER R 3/4 Z. POM-COPLYMER HASO	SLEEVE NUT R 3/4" Z. POM-COPLYMER HASO	ECROU RACCORD R 3/4"Z. POM-COPLYMER HASO
6	0233038	NORMA-KLEMME 1248170020 SCL 16-25/9 SKZ W4 V2A	CLAMP-NORMA 1248170020 SCL 16-25/9 SKZ W4 V2A	BORNE-NORMA 1248170020 SCL 16-25/9 SKZ W4 V2A
7	0630218	SCHLAUCH GLASKLAR 13 X 3,5MM PVC MIT GEWEBE	TRANSPARENT HOSE D=13 X 3,5	TUYAU FLEXIBLE TRANSPAR. 13 X 3,5 MM PVC AVEC TIS.
8	0233048	SCHLAUCHKLEMME SGL 20-32/9 W4 V2A	HOSE CLAMP SGL 20-32/9 W4 V2A	BORNE DE TUYAU SGL 20-32/9 W4 V2A
9	0650010	TUELLE 1532 GUMMI FA.SCHENK	RUBBER BUSHING	DOUILLE EN CAOUTCHOUC
10	0340010	U-SCHEIBE 1.4301 6,3X16X1,5 MM	WASHER 4301 16 X 6,3 X 1,5 MM	RONDELLE 16 X 6,3 X 1,5MM 4301
11	0337001	SKT.-MUTTER M 5 A4 SELBSTSICH. DIN 985	HEXAGON NUT SELF FIXING M5 4401 DIN 985	ECROU A SIX PANS M5 4401 DIN 985

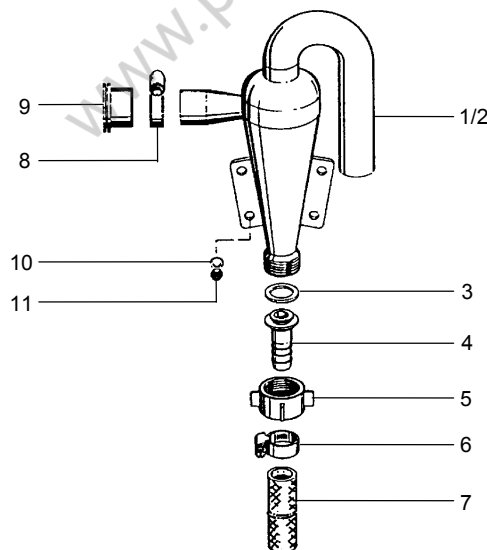

ird\image-in\30000071

Das Programm auf einen Blick

Spülautomaten mit stationärem Waschverfahren

Geschirrspülautomaten, Topf- und Behälterspülautomaten, Gläserspülautomaten, Universalspülautomaten, Salat- und Gemüsewaschautomaten

Spülautomaten mit Durchlaufsystem

Geschirrspülautomaten mit automatischem Bandtransport, Geschirrspülautomaten mit automatischem Korbtransport

Spezialspülanlagen

Vollautomatische Spülanlagen für Geschirr, Tablett- und Besteck, Flight-Catering-Anlagen zur Entsorgung, Reinigung und Wiederbereitstellung von Geschirr und Gerätschaften der Bordverpflegung im Luftverkehr, Industriespülautomaten für spezifisches Waschgut, Trolley-, Behälter- und Transportwagenspülautomaten

Förderanlagen

Tablett- und Geschirrtransportbänder, Geschirrsortier- und Stapleinrichtungen, Vertikalförderer

Speisereste-Anlagen

Maschinen und Anlagen zur Behandlung von Speiseresten für eine umweltgerechte Entsorgung

Großkücheneinrichtungen

Geräte und Mobiliar für Relais- und Stationsküchen; Transportwagen, Tablett- und Tellerstapler, Tische, Schränke und Regale aus Edelstahl, diverse Organisationsmittel

MEIKOLON Reinigungs- und Hygieneprodukte

für Gläser-, Geschirr- und Universalwaschautomaten

Reinigungs- und Desinfektionsgeräte für Krankenhäuser und Heime

Reinigungs- und Desinfektionsautomaten für Steckbecken und andere Pflegegeschirre als Stand-, Wand- und Einbaugeräte, Pflegekombinationen, Installationsblocks für die Sanitärzone im Krankenzimmer, Komplettausstattungen für unreine Arbeitsräume



Gemäß der Hygieneanforderung der DIN 10511-H für gewerbliches Gläserspülen, DIN 10510 für gewerbliches Geschirrspülen und DIN 10522 für gewerbliches Spülen von Mehrwegkästen, -behältnissen.



MEIKO Maschinenbau GmbH & Co. KG
Englerstr. 3 · 77652 Offenburg · Germany
Tel. +49(0)781/203-0 · Fax +49(0)781/203-1174
www.meiko.de · E-Mail: info@meiko.de

